

EMPOWERING TEACHERS: THE INFLUENCE OF TRANSFORMATIONAL
LEADERSHIP IN CHRISTIAN SCHOOLS

A Dissertation Presented to
The Faculty of the School of Education
Liberty University

In Partial Fulfillment
of the Requirements for the Degree
Doctor of Education

By
John Irungu Kirika
June, 2011

Empowering teachers: The Influence of Transformational Leadership in Christian
Schools

By John Irungu Kirika

APPROVED:

COMMITTEE CHAIR

Tracey B. Pritchard, Ed.D

COMMITTEE MEMBERS

Glenn R. Holzman, Ph.D

Charles K. Smith, Ph.D

CHAIR, GRADUATE STUDIES

Scott B. Watson, Ph.D

ABSTRACT

John Irungu Kirika. EMPOWERING TEACHERS: THE INFLUENCE OF
TRANSFORMATIONAL LEADERSHIP IN CHRISTIAN SCHOOLS

(Under the direction of Dr. Tracey B. Pritchard). School of Education, June, 2011.

The object of this study was to investigate transformational leadership in Christian schools. The study investigated the perception of empowerment of K-12 Christian school teachers and its influence on organizational and professional commitment and job satisfaction. It explored correlations between teacher empowerment and selected demographic variables. The study also investigated how K-12 Christian school leaders and teachers perceive teacher empowerment. A combination of causal comparative and a correlational research method using a series of t-test, ANOVA, and multiple regression statistics was used for parametric statistical analyses. The research findings were mixed. While the study pointed to the prevalence of teacher empowerment in K-12 Christian schools, teachers did not feel empowered in certain dimensions or subscales of teacher empowerment.

Dedication

I am proud to dedicate this dissertation to my family.

To my wife, Dr. Jane Njeri Irungu, in heartfelt appreciation of her unwavering support and understanding during the arduous academic process.

To our three beloved children: Beth Lucy Wairimu Irungu, Polly Lucy Njoki Irungu, and Matthew Kirika Irungu. My earnest prayer for you is that you will always abide in Christ, who gives life in abundance.

To my parents: Jehoshat Kirika (deceased three years ago), and Lucy Wairimu Kirika. In spite of having no formal education, they instilled in me the importance of education. Thank you for teaching me the value of integrity, hard work, and sacrifice. These were the pillars of your success.

To my parents-in-law, Joseph Ngigi Nyamu and Lucy Njoki, whose faith in Christ, love, prayers, hard work, and sacrifices are treasures deeply appreciated.

Finally, to the battalion of dedicated teachers who inspired me and whom God used to intellectually and spiritually mold me to become the person I am today, a person dedicated to the cause of serving others for the good of humanity and ALL for the glory of God.

Acknowledgements

The realization of a doctorate degree is the pinnacle of my academic pursuit. I wholeheartedly acknowledge and appreciate the invaluable support that I have received along the way. First and foremost, I thank my God for bestowing abundant grace and mercies upon me. God's provisions made this academic endeavor come to fruition.

I am deeply indebted to my doctoral dissertation committee consisting of Dr. Tracey B. Pritchard, the chair, and members, Dr. Glenn Holzman and Dr. Charles K. Smith, for their adept advisory support, academic guidance, and encouragement, which made this endeavor become a noble reality. I am also grateful for the contribution garnered from Dr. Darrin Graham, who was part of the team at some time in the process.

Dr. Tracey B. Pritchard, thank you for your superb devotion to scholarship and the remarkable display of leadership acumen, diligence, and patience during the strenuous but enlightening academic process.

May the good Lord richly reward and bless you all!

Table of Contents

| | |
|--|----|
| Dedication | iv |
| Acknowledgements..... | v |
| List of Tables | vi |
| List of Figures | xi |
| CHAPTER ONE: INTRODUCTION..... | 1 |
| Background of the Study | 1 |
| Statement of the Problem..... | 5 |
| Purpose of the Study | 6 |
| Significance of the Study | 6 |
| Research Questions..... | 7 |
| Statement of Hypotheses..... | 8 |
| Definitions..... | 12 |
| Summary of the Study | 14 |
| CHAPTER TWO: REVIEW OF LITERATURE..... | 15 |
| The Phenomenon of Leadership: An Introduction..... | 15 |
| Theoretical Framework of the Study | 15 |
| Transformational Leadership | 17 |
| Transformational Leadership and Empowerment in Educational Setting | 20 |
| Organizational and Personal Outcomes | 21 |
| Organizational Commitment..... | 22 |
| Professional Commitment..... | 22 |
| Job Satisfaction | 22 |

| | |
|--|----|
| The Construct of Empowerment | 23 |
| An Overview of Power and Empowerment in Schools | 23 |
| Transformational Leadership and Teacher Empowerment in Christian Schools | 25 |
| Leadership: A Christian Perspective..... | 27 |
| Visionary Christian Leadership | 29 |
| Leadership and Teacher Empowerment in General School Context | 31 |
| Further Delineation of Empowerment in Corporate and Educational Settings | 32 |
| Benefits of Teacher Empowerment | 33 |
| Inner Leadership Qualities | 40 |
| The Need for Organizational Commitment | 42 |
| The Need for Professional Commitment (Job Involvement)..... | 43 |
| The Need for Job Satisfaction..... | 44 |
| Leadership and Power..... | 45 |
| Negative Principal Practices | 46 |
| Chapter Summary | 48 |
| CHAPTER THREE: METHODOLOGY | 49 |
| Introduction..... | 49 |
| Restatement of Research Questions..... | 49 |
| Restatement of Hypotheses..... | 50 |
| Research Design..... | 54 |
| Participants..... | 57 |
| Settings..... | 58 |
| Research Instruments | 58 |

| | |
|--|-----------|
| Instrument Reliability | 62 |
| Data Analysis | 63 |
| Procedure | 65 |
| Data Collection Process | 66 |
| Data Preparation..... | 68 |
| CHAPTER FOUR: RESULTS | 69 |
| Demographic Profile of the Population | 69 |
| Educational Attainment | 69 |
| Years of Service in School Setting | 70 |
| Gender..... | 71 |
| Size of School | 71 |
| Research Questions and Hypotheses Testing | 72 |
| Research Question 1 | 72 |
| Research Question 2 | 75 |
| Research Question 3 | 79 |
| Research Question 4 | 80 |
| Research Question 5 | 84 |
| Summary of Research Results | 85 |
| CHAPTER FIVE: DISCUSSION OF FINDINGS AND IMPLICATIONS | 87 |
| Discussion of Research Findings | 87 |
| Hypothesis 1..... | 87 |
| Hypothesis 2..... | 90 |
| Hypothesis 3..... | 92 |

| | |
|--|-----|
| Hypothesis 4..... | 93 |
| Hypothesis 5..... | 95 |
| Implications of the Study | 96 |
| Other Incidental Findings | 97 |
| Limitations of the Study | 98 |
| Summary of the Findings..... | 100 |
| Recommendations for Future Research | 103 |
| REFERENCES | 104 |
| APPENDICES | 119 |
| Appendix A-School Participant Empowerment Scale (SPES) | 119 |
| Appendix B- Organizational Commitment Questionnaire (OCQ) | 122 |
| Appendix C- Bolin's (1989) Teacher Empowerment Scale..... | 124 |
| Appendix D- Job Involvement Questionnaire (JIQ)..... | 125 |
| Appendix E- Michigan Organizational Assessment Questionnaire- Job Satisfaction Subscale (MOAQ-JSS)/ Overall Job Satisfaction..... | 127 |
| Appendix F-Demographics Questionnaire | 128 |
| Appendix G- Invitation and Informed Consent | 129 |
| Appendix H- Permission to Use School Participant Empowerment Scale (SPES) | 131 |
| Appendix I- Permission to Use Organizational Commitment Questionnaire (OCQ) | 133 |
| Appendix J- Liberty University Internal Review Board (IRB) Research Approval..... | 135 |
| Appendix K- Request to Participate in Dissertation Research Email..... | 137 |

List of Tables

| | |
|--|----|
| Table 1: Reliability of Instruments | 63 |
| Table 2: Highest Level of Education | 70 |
| Table 3: Participants' Years of Service in School Setting..... | 71 |
| Table 4: Size of School Based on Total Student Enrollment | 72 |
| Table 5: Descriptive Statistics for the School Participant Empowerment Scale | 73 |
| Table 6: Zero-Order Correlations | 78 |
| Table 7: Regression Coefficients for Teacher Empowerment/Demographics | 80 |
| Table 8: Summary of Results | 85 |

List of Figures

| | |
|--|----|
| Figure 1: Significant Levels of Perceived Empowerment | 75 |
| Figure 2: Effects of Teacher Empowerment | 77 |
| Figure 3: Dimensions (or Subscales) of Teacher Empowerment | 83 |

CHAPTER ONE: INTRODUCTION

There is a rich body of research literature in the province of leadership, primarily encompassing corporate entities and public institutions (Bennis & Nanus, 2003). In the domain of education, empirical literature reveals that a good number of studies have explored the leadership practices of public school principals (Bass, 1990; Bass & Avolio, 1990; Fiedler, 1967; Hickman, 1998; Yukl, 1998), but none of these examined Christian school systems within a conceptual framework (Shee, Ji, & Boyatt, 2002). It is, therefore, apparent that research on leadership practices forged in Christian schools has been lacking. This study was instituted primarily to address this research void. In light of the growing number of Christian schools in America and the challenges of Christian school leadership, the need for gaining understanding about leadership practices prevailing in these schools, through empirical inquiry, cannot be overstated. This present study was carried out to investigate the prevalence of teacher empowerment as a construct of transformational leadership and its impact on K-12 Christian school teachers' behaviors regarding their job satisfaction and commitment to both their schools and the profession.

Background of the Study

The rationale for conducting this empirical study is based on a number of factors. First, educational reforms have largely been the domain of public schools, and little attention has been directed at private schools in the research arena. This is congruent with observations made by Braggs (2008) to the effect that there were too many gaps in the understanding of transformational leadership or empowerment and its benefit to

Christian schools. As a result, private schools and the experiences of teachers in those schools have been largely ignored in the preponderance of educational reform literature.

Second, given the growing role of transformational leadership, with its effects on school outcomes (and with empowerment of teachers being its mainstay), it is important to examine and understand how teachers view themselves within these efforts. In a nutshell, it is important to examine empirically the level of teacher empowerment in Christian schools and its implications for their organizational commitment and shared leadership, otherwise referred to as transformational leadership. These variables were chosen because they predict school effectiveness (Howell & Dorfman, 1996; Rosenholtz, 1991).

This study sought to understand whether teachers in Christian schools are empowered enough to be partners in shared school leadership. It also investigated Christian school teachers' organizational commitment to their schools. These four constructs (teacher empowerment, organizational commitment, professional commitment, and job satisfaction) are presumed to shed light on benefits of effective and authentic transformational leadership.

This study will add to the limited body of literature currently available in the domain of teacher empowerment or leadership in Christian schools. Further, the findings may benefit school leaders, teachers, and other stakeholders in Christian schools as they adapt the concepts of teacher empowerment as a new paradigm for good school leadership and predictably better academic outcomes. The future and the success of K-12 Christian education rest on organizations and their ability to train and attract those with the best in leadership qualities to lead a purpose-driven movement toward the prevailing

and coming challenges, while earning honor, respect, and legitimacy among the American population (Braggs, 2008).

Never before has there been such a critical need for leadership in both private and public schools. The *Nation at Risk Report* of 1983, which was conducted under the auspices of the U.S. Department of Education, brought to the nation's attention the fact that all was not well with American public education. The findings revealed debilitating problems in those things that constitute the bone and marrow of education: curriculum content, standards and expectations, time, teacher quality, leadership, and financial support. The report further served as an indictment of educational officials, school leaders, and the American public for complacency. The university presidents, eminent scientists, policymakers, and educators who made up the commission refused to provide a false depiction of the eroding quality of American education. The commission said that Americans had become self-satisfied about the country's leading position in the world and had lost sight of the basic purposes of schooling and of the high expectations and disciplined effort needed to attain them (National Commission on Excellence in Education, 1983). This grim reality helped engineer a myriad of reform movements bent on infusing changes in school leadership, curriculum, and academic standards. The advocacy for and the implementation of a site-based school leadership model, the Teacher Empowerment Act, and the No Child Left Behind Act of 2002 are prime examples of these efforts.

In 2008, the U.S. Department of Education revisited the issue with the new report titled *A Nation Accountable Twenty-five Years After a Nation at Risk*. Although there was some progress noted in the new report (mainly in the area of student assessment), the

bulk of the findings were still dismal. According to the report, America remained a nation at risk, albeit also a nation informed, a nation accountable, and a nation that recognized there was much work to be done. The report highlighted the fact that America was at even greater risk than in 1983. In addition, the report posited that the rising demands of the global economy, together with demographic shifts, required that the United States educate more students to higher levels than ever before. In spite of this reality, the American education system was observed as not keeping pace with the growing demands.

The epic challenges faced by educators call for dynamic, transformational leaders. In a letter to Thomas Jefferson in 1790, Abigail Adams wrote, “These are hard times in which a genius would wish to live. Great necessities call forth great leaders” (as cited in Bennis & Nanus, 2003, p.1). It is apparent that hard times demand great leaders who can steer people out of the plethora of problems they are facing. In particular reference to the realm of education, both public and private schools are in critical need of leadership more than ever before due to growing concerns over performance and improvement (Fullan, 2007). For schools to meet the needs of American society in the 21st century, they will need to transform themselves from institutions bent on compliance and attendance to ones that nurture commitment and attention (Fullan, 2007). Therefore, the school’s core business should consist of those things on which its attention is fastened and its energy directed toward the attainment of optimal personal and organizational outcomes (Schlechty, 2002). This, in practice, will foster a transformation that not only defines the school’s critical roles, but will also expand the role of teachers to include a stake in the decision-making process (Schlechty, 2002). In order for this to happen,

school leaders must empower teachers, and teachers must accept the responsibility that comes with empowerment (Schlechty, 2002).

Statement of the Problem

Empowerment of teachers is a critical element of reform efforts to improve schools and, consequently, to foster superior educational outcomes (Eckley, Rinehart, & Short, 1999). Eckley, Rinehart, and Short (1999) further observed that the most important attempt in creating empowering school environments is the model of leadership the principal perpetuates. Kelly (2000) observed that the quality and the improvement of American public schools are threatened by crises in school leadership. Christian schools are also not immune to these perennial leadership problems. Davies (1993) observed that many Christian schools appear to operate within an organizational structure that is consistent with the bureaucratic and hierarchical model propounded by Weber in 1924. Max Weber, a German sociologist, propounded a theory of authority structures in which he identified an organizational format he named bureaucracy (as cited in Davies, 1993). The striking feature of a bureaucracy was a definition of roles within a hierarchy, where employees were appointed on merit, required to follow rules, and expected to behave impartially (Cole, 2004).

For Christian school leaders to avoid the problems of discipline, dismal academic performance, crime, school dropouts, teacher retention, and dissatisfaction, they have to adopt the concepts that have been proven to be critical for school success (Demuth & Demuth, 2007; Noll, 2003). These concepts are enshrined in transformational leadership and include the personal and organizational outcomes associated with it. In this vein, the prevalence of teacher empowerment and both organizational and personal commitment,

as attributes of transformational leadership in K-12 Christian schools, requires empirical scrutiny.

Purpose of the Study

The purpose of this study was to investigate the construct of teacher empowerment and its influence on teachers' commitment to their schools and their profession and on their job satisfaction. The study sought to investigate what dimensions of empowerment (autonomy, decision-making, impact, self-efficacy, and professional growth) can best predict the aforementioned variables. Finally, the study sought to examine any disparity between school leaders' and teachers' perception of teacher empowerment.

The Significance of the Study

The implications of this study for the practice of education and pedagogy of transformational leadership and teacher empowerment are paramount. The study provides elucidation on the construct and practices of transformational leadership. The study is poised to add to the understanding of teacher empowerment construct as an outcome of transformational leadership and any link with job satisfaction and organizational and professional commitment within the setting of K-12 Christian schools. The quantitative findings collected should add to the limited data currently available in the arena of Christian schools and transformative leadership. Furthermore, the research findings will inform school leaders and other stakeholders of the dynamic resources and benefits of transformational leadership and teacher empowerment, both of which can be harnessed to achieve excellent school outcomes.

The results of this study will assist Christian leaders in the transformation of their schools to achieve excellent educational outcomes and exemplary professional growth through the empowerment of teachers. By empowering teachers, leaders can help create synergistic learning communities. In reality, progressive schools in the 21st century should be seen as communities of learners capable of transforming themselves and shaping both the community and school culture (Fullan, 2007).

Empowered teachers are more resourceful and more committed to their schools (Ingersoll, 2003). Therefore, transforming principal leadership and the empowerment of teachers that accrues from it should be regarded as an essential paradigm in schools, and Christian school leaders who desire to transform their schools in order to achieve excellent educational outcomes and professional growth should foster an enabling environment of teacher empowerment. School leaders should seek to empower teachers through informal sharing of power, delegation, and consultative decision-making (Davies, 1993). In addition, Davies (1993) postulated that authentic information sharing among teachers instills a sense of corporate belonging and invigorates them to effectively strive toward corporate goals.

Research Questions

1. What are the perceptions of K-12 Christian school teachers regarding teacher empowerment?
2. What are the effects of perceived teacher empowerment on their job satisfaction and commitment to both their schools and the teaching profession?

3. Does a teacher's gender, level of education, years of educational experience, school type, and school size affect his/her perceptions regarding teacher empowerment?
4. What dimensions of perceived teacher empowerment (autonomy, decision-making, impact, professional growth, self-efficacy, and status) can best predict teachers' commitment to their schools and their profession, and teachers' job satisfaction?
5. Is there a significant difference between teachers' and principals' perceptions of teacher empowerment?

Statement of the Hypotheses

The following null hypotheses and sub-hypotheses were formulated to test the research variables noted above.

Hypothesis 1

- H₀1₁ There is no significant level of perceived teacher empowerment related to decision-making as measured by School Participant Empowerment Scale (SPES).
- H₀1₂ There is no significant level of perceived teacher empowerment related to autonomy as measured by School Participant Empowerment Scale (SPES).
- H₀1₃ There is no significant level of perceived teacher empowerment related to professional growth as measured by School Participant Empowerment Scale (SPES).

H₀1₄ There is no significant level of perceived teacher empowerment related to impact as measured by School Participant Empowerment Scale (SPES).

H₀1₅ There is no significant level of perceived teacher empowerment related to status as measured by School Participant Empowerment Scale (SPES).

H₀1₆ There is no significant level of perceived teacher empowerment related to self-efficacy as measured by School Participant Empowerment Scale (SPES).

Hypothesis 2

The perception of empowerment of K-12 Christian school teachers has no significant correlation with their commitment to their schools and their profession, and their job satisfaction as measured by Michigan Organizational Assessment Questionnaire-Job Satisfaction Subscale (MOAQ-JSS), Organizational Commitment Questionnaire (OCQ), and the Job Involvement Questionnaire (JIQ).

H₀2₁ The perception of empowerment of K-12 Christian school teachers has no significant correlation with commitment to their schools.

H₀2₂ The perception of empowerment of K-12 Christian school teachers has no significant correlation with commitment to their profession.

H₀2₃ The perception of empowerment of K-12 Christian school teachers has no significant correlation with their job satisfaction.

Hypothesis 3

The K-12 school teacher's gender, level of education, school type, and school size have no significant effect on the perception of their empowerment as measured by School Participant Empowerment Scale (SPES).

H₀3₁ Gender does not have a significant effect on a teacher's perception of their empowerment.

H₀3₂ Level of education does not have a significant effect on a teacher's perception of their empowerment.

H₀3₃ School type does not have a significant effect on a teacher's perception of their empowerment.

H₀3₄ Size of school does not have a significant effect on a teacher's perception of their empowerment.

Hypothesis 4

The teachers' perceived empowerment dimensions of autonomy, decision making, impact, professional growth, self-efficacy, and status are not significant predictors of their organizational commitment, professional commitment, and job satisfaction as measured by School Participant Empowerment Scale (SPES), Organizational Commitment Questionnaire (OCQ), Job Involvement Questionnaire (JIQ) (Professional Commitment), and Michigan Organizational Assessment Questionnaire Job Satisfaction Subscale (MOAQ-JSS).

H₀4₁ The teachers' perceived empowerment dimension of autonomy is not a significant predictor of their organizational commitment.

- H₀₄₂ The teachers' perceived empowerment dimension of autonomy is not a significant predictor of their professional commitment.
- H₀₄₃ The teachers' perceived empowerment dimension of autonomy is not a significant predictor of their job satisfaction.
- H₀₄₄ The teachers' perceived empowerment dimension of decision making is not a significant predictor of their organizational commitment.
- H₀₄₅ The teachers' perceived empowerment dimension of decision making is not a significant predictor of their professional commitment.
- H₀₄₆ The teachers' perceived empowerment dimension of decision making is not a significant predictor of their job satisfaction.
- H₀₄₇ The teachers' perceived empowerment dimension of impact is not a significant predictor of their organizational commitment.
- H₀₄₈ The teachers' perceived empowerment dimension of impact is not a significant predictor of their professional commitment.
- H₀₄₉ The teachers' perceived empowerment dimension of impact is not a significant predictor of their job satisfaction.
- H₀₄₁₀ The teachers' perceived empowerment dimension of professional growth is not a significant predictor of their organizational commitment.

- H₀₄₁₁ The teachers' perceived empowerment dimension of professional growth is not a significant predictor of their professional commitment.
- H₀₄₁₂ The teachers' perceived empowerment dimension of professional growth is not a significant predictor of their job satisfaction.
- H₀₄₁₃ The teachers' perceived empowerment dimension of self-efficacy is not a significant predictor of their organizational commitment.
- H₀₄₁₄ The teachers' perceived empowerment dimension of self-efficacy is not a significant predictor of their professional commitment.
- H₀₄₁₅ The teachers' perceived empowerment dimension of self-efficacy is not a significant predictor of their job satisfaction.
- H₀₄₁₆ The teachers' perceived empowerment dimension of status is not a significant predictor of their organizational commitment.
- H₀₄₁₇ The teachers' perceived empowerment dimension of status is not a significant predictor of their professional commitment.
- H₀₄₁₈ The teachers' perceived empowerment dimension of status is not a significant predictor of their job satisfaction.

Hypothesis 5

- H₀₅ There will be no significant difference in how principals and teachers perceive teacher empowerment as measured by Bolin's Teacher Empowerment Scale.

Definitions

The following are definitions important to this study.

1. *Empowerment* is defined as “investing teachers with the right to participate in the determination of school goals and policies and to exercise professional judgment about what and how to teach” (Borin, 1989, p. 82). It consists of “enabling experiences provided within an organization that fosters autonomy, choice, control, and responsibility” (Short & Rinehart, 1992a, p. 952). Further, it is also associated with terms such as shared governance, shared decision making, and teacher leadership.
2. A *Christian school* in this study is defined as a school that strives to honor Jesus Christ in all it does by using the Word of God (the Bible) as the guide and rule for every area of philosophy and education, including planning, policies, curriculum, and interaction among teachers, parents, students, and administration (Lee, 2005). It is further defined by membership in the Association of Christian Schools International (ACSI, 2009).
3. *Organizational commitment* was defined by Mowday, Steers, and Porter (1979) as a strong belief in and acceptance of the organization’s goals and values; a willingness to exert considerable effort on behalf of the organization; and a strong desire to maintain membership in the organization.
4. *Status* refers to the teacher’s sense of esteem and professional respect, given to the teacher by students, parents, supervisors, and the community (Ashton & Webb, 1986).

5. *Job involvement* is defined as "psychological identification with a job" (Kanungo, 1982, p. 97). This definition implies that a job-involved person sees her or his job "as an important part of his self-concept" (Lawler & Hall, 1970, p. 311) and that jobs "define one's self-concept in a major way" (Kanungo, 1982, p. 82).
6. *Autonomy* as a dimension of an empowerment model refers to the teachers' belief that they have the control of important aspects of their lives (Short & Rinehart, 1992a).
7. *Teacher impact* is defined as the teachers' perceptions that they have influence over their work life (Short & Rinehart, 1992a).
8. *Global score* is the mean score of School Participant Empowerment Scale's six subscales or dimensions: decision making, autonomy, status, professional growth, and impact.

Summary of the Study

This study was conducted to provide insight on teacher empowerment as a construct of transformational leadership and its effect on job satisfaction and both organizational and professional commitment. The insight gleaned from this study will assist leaders in K-12 Christian schools to become dynamic, transforming leaders who are capable of effectively empowering their teachers. It is also hoped that such leaders will nurture and inculcate a culture of transforming behaviors. Outstanding leadership has been observed to be a key characteristic of successful schools, and the schools that are seeking quality education must embrace and nurture exemplary leadership and attach paramount importance to the development of potential leaders (Beare, Caldwell, & Millikan, 1989).

CHAPTER TWO: REVIEW OF LITERATURE

The Phenomenon of Leadership: An Introduction

Maxwell's (2007) observation that everything rises and falls on leadership is axiomatic. This axiom attests to the paramount importance of leadership. It is a universal concept that pervades every facet of human enterprise, including business, government, church, and education (Fullan, 2007). Leadership is a complex phenomenon, the true meaning of which continues to baffle many students of leadership. Burns (1977) reckoned leadership as one of the most misunderstood phenomena despite a plethora of studies devoted to it. There is little consensus on the meaning of leadership or what constitutes good leadership. However, every study on leadership has the potential to bring elements of enlightenment to the subject.

According to Schultz (1998), education is vital in bringing a better understanding of and molding the destiny of man or society at large. Education is an important resource for transforming leadership, and it is, therefore, imperative to foster its development in every sphere of human endeavor. It is through education and learning that leadership can be mastered as an instrument that informs and influences human behavior and its consequent outcomes.

Theoretical Framework of the Study

This study was framed within the praxis of leadership with the belief that leadership is the pivotal force behind successful institutions (Bennis & Nanus, 2003). In order to create these vital and viable organizations, leadership is necessary to help them develop a vision of what they can become and steer them to conform to that vision

(Bennis & Nanus, 2003). As noted above, the phenomenon of leadership is a fascinating one, but the meaning remains largely elusive (Rosenbach & Taylor, 1998). This lack of universal definition exists in spite of the explosion of voluminous research studies in the province of leadership, notably after the 1978 publication of *Leadership* by James M. Burns.

Burns (1978) defined leadership as leaders inducing followers to act for certain goals that represent the values and the motivations (their wants and needs), the aspirations, and the expectations of both leaders and followers. According to Burns (1978), a leader is a person who instills purpose and does not wield control by brute force, strengthens and inspires the followers to accomplish shared goals, shapes the organization's values, promotes the organization's values, protects the organization's values, and ultimately exemplifies the organization's values. Burns (1978) also explained,

Leaders foster appropriate changes by tapping into and shaping common values, goals, needs, and wants to develop and elevate others in accordance to the agreed upon values. Leaders address the needs, wants, and values of their followers (and their own) and, therefore, serve as an independent force in changing the makeup of the followers' values set through gratifying their motives. (p. 20)

Bennis (1989) articulated leadership to be the capacity to create a compelling vision, translate that vision into action, and sustain it. Bennis (1989) further observed that leadership is important because it creates organizational effectiveness, stability, and integrity.

A growing theme from studies on leadership beckons new paradigms in leadership and calls for leaders to be catalysts for change (Bass & Riggio, 2006; Bennis

& Nanus, 2003; Kouzes & Posner, 2002). These paradigms consist in leadership models such as moral, servant, and transformational leadership. Within the framework of transformational leadership are constructs such as empowerment, organizational commitment, professional commitment, and good citizenship (Bogler & Somech, 2004; Givens, 2008; Short & Pounder (1994). The construct of empowerment, as an outcome of transformational leadership, enhances both personal and organizational success (Short, 1994). In further support of this view, other research studies have revealed correlations of empowerment and positive organizational and personal outcomes (Bogler & Somech, 2004).

In this study the researcher ventured to explore, not the process of transformational leadership, but its outcomes as related to Christian schools. This enquiry was framed and focused by the desire to comprehend the ideals of transformational leadership, as well as its tributary construct of teacher empowerment and consequent principal and teacher behaviors. The optimum goal of this study was to investigate whether leaders in Christian schools practiced the fundamental ideals of transformational leadership. These ideals consist in leaders' practices of sharing power with, rather than having power over, their followers (Kreisberg, 1992). This practice constitutes the principle of empowerment. As observed by Kreisberg (1992), the construct of empowerment is enshrined in transformational leadership.

Transformational Leadership

With the theoretical framework of transformational leadership theory extensively expounded in the literature review, this researcher investigated the prevalence or practices of transformational leadership in K-12 Christian schools and the relationship

between teacher empowerment and other selected demographic variables. In order to gain this understanding, the study focused on the object of exploring whether Christian schools are transformative, as gauged by the empowerment of teachers and whether the teachers perceive themselves as empowered. If the teachers are empowered, how does that empowerment impact their commitment to the organization (the school) and profession, and job satisfaction? Do the school leaders and teachers perceive teacher empowerment the same way? In other words, this study investigated whether there is any disparity between principals' and teachers' perceptions of empowerment. The study also attempted to determine which subscales of teacher empowerment best predicted organizational commitment, professional commitment, and job satisfaction.

Transformational leadership is a well documented and validated leadership phenomenon studied in management and in organizational realms (Noland, 2005). This study applies the construct of transformational leadership to teacher empowerment and its effect on behavior of teachers in K-12 Christian schools. According to Givens (2008), transformational leadership theory has captured the interest of many researchers in the field of organizational leadership over the past three decades. This theory was initially developed by Burns (1978) and later refined and expanded by a variety of researchers (Avolio & Bass, 2002; Bass & Avolio, 1994; Bennis & Nanus, 2003; Tichy & Devanna, 1986). According to Burns (1978), transformational leadership is a process by which leaders and followers facilitate advancement to a high level of morality and motivation.

Bass (1990) developed this concept further and defined transformational leadership in terms of how the leader affects followers. In this respect, the followers are

intended to trust, admire, and respect the transformational leader. Bass (1998) identified three ways in which leaders transform followers: increasing their awareness of task importance and value, getting them to focus first on team or organizational goals rather than their own interests, and activating their higher-order needs.

Burns (1978) differentiated two sets of leadership: transactional and transforming. He observed transactional leadership to be more common and to involve the exchange of incentives by leaders for support from followers. In politics for instance, jobs are exchanged for votes, or subsidies for campaign contributions. The object of such leadership is agreement on a course of action that satisfies the immediate, separate purposes of both leaders and followers (Ciulla, 2004).

Transforming leadership, on the other hand, does not aim to satisfy immediate needs but instead looks for potential motives in followers, seeks to satisfy higher needs, and engages the full person of the follower. The goal of transforming leadership is to convert self-interest into collective concerns and aspirations (Ciulla, 2004). For Burns (1978), transforming leadership is superior to transactional leadership, and it is motivating, uplifting, and moral as it focuses on raising the level of human conduct and ethical pursuits of the leader and followers. Burns (1978) observed leadership to be a conduit for change and a platform for sharing common purposes and values. In transforming leadership, followers are empowered to change their lives for the better, as well as the lives of others within the circle of their influence. Transforming leaders ascribe to higher ideals of liberty, equality, and community (Ciulla, 2004). They also embrace and perpetuate the principles of visionary, moral, and servant leadership (Ciulla, 2004; Kouzes & Posner, 2002; Sergiovanni, 1992). Transformative leaders are the ones

who shape and elevate the motives and aspirations of followers. By doing so, transformative leaders help forge significant change that reflects the community of interests of both the leader and the followers, thereby pooling the collective energies in pursuit of common vision and goals (Bennis & Nanus, 2003).

The salient premise of transformational leadership theory was observed to be the leader's ability to motivate followers to accomplish more than what the followers planned to accomplish (Krishnan, 2005). This theory has been positively associated with a variety of organizational and personal outcomes such as organizational commitment, professional commitment, and job satisfaction (Bryman, 1992). Masi and Cooke (2000) posited that transformational leaders utilize the behavior that empowers their followers and enhances their motivation. When leaders of organizations empower their followers, many benefits can be reaped. Bogler and Somech (2004) conducted a study on teacher empowerment and found it to be positively correlated to organizational commitment, professional commitment, citizen behavior, and job satisfaction. The four constructs (empowerment, organizational commitment, professional commitment, and job satisfaction) were the key variables under investigation in this empirical study.

Transformational Leadership and Empowerment in Educational Setting

The transformational leadership model has dominated leadership research studies in the past decade (Avolio, Eden, & Shamir, 2002). Transformational leadership is a leadership style that inculcates dynamic and positive change (Bennis & Nanus, 2003). A transformational leader focuses on transforming others by encouraging them to care for each other and work as a team, with the object of realizing common aspirations (Bass & Avolio, 1995). In this leadership model, the leader utilizes behavior that empowers

followers and forges follower motivation (Masi & Cooke, 2000). This empowerment is the outcome of transformational leadership (Kelley, 1998).

The theoretical concept of empowerment rests on a well-grounded body of research, which started in the field of business and later expanded to other fields, including education (Short, 1994). In the educational setting, the central theme of transforming school leaders is teacher empowerment, which has also been the central focus of school reform movements over the years (Pounder, 1998; Short, 1998). Empowerment is defined as “investing teachers with the right to participate in the determination of school goals and policies and to exercise professional judgment about what and how to teach” (Borin, 1989, p. 82). It consists of enabling experiences provided within an organization that fosters autonomy, choice, control, and responsibility (Short, 1998). In essence, teacher empowerment translates to “participative decision-making and shared leadership” (Short & Rinehart, 1992a, p. 952).

Organizational and Personal Outcomes

Organizational Commitment

The concept of empowerment has been associated with positive organizational and personal outcomes, including organizational and professional commitment and job satisfaction (Bogler & Somech, 2004; Bryman, 1992). Organizational commitment is the relative strength of an individual’s identification with and involvement in a particular organization (Mowday, Steers, & Porter, 1979). The concept of organizational commitment is based on the acceptance of the organization’s goals and values (identification), the willingness to invest effort on behalf of the organization (involvement), and the importance attached to keeping the membership in the

organization (loyalty) (Bogler & Somech, 2004). Organizational commitment has been positively related to better teacher performance and retention (Bogler & Somech, 2004; Egley, Henkin, & Park, 2005).

Professional Commitment

Professional commitment or job involvement is defined as the extent to which one identifies psychologically with one's work (Kanungo, 1982). Theoretically, individuals who are more involved in their jobs should exert more effort (Brown & Leigh, 1996). Brown and Leigh (1996) also found that job involvement was positively related to job performance through effort. Professional commitment was further observed to be the "degree to which a person's work performance affects his self-esteem" (Lodahl & Kejner, 1965, p. 25). A person that is professionally committed sees work as a vital part of life, and this means that both the work itself and the co-workers generate great meaning, fulfillment, and attachment (Bogler & Somech, 2004).

Job Satisfaction

Job satisfaction is most often conceptualized as a positive emotional state relating to one's job (Camman, Lawler, Mirvis, & Seashore, 1983). It has been defined as "a pleasurable or positive emotional state resulting from the appraisal of one's job and job experience" (Locke, 1976, p. 1304). It accrues from a person's perception that the job generates what he or she values in the work setting (Denessen, Nguni, & Slegers, 2006). Research studies have revealed that leadership behavior has a direct bearing on employees' job satisfaction (Griffin & Bateman, 1978). A study conducted by Maeroff (1998) also found job satisfaction to be positively associated with transformational leadership.

The Construct of Empowerment

Empowerment of followers is an important process that both helps define transformational leadership, and demonstrates why it is effective in enhancing follower commitment and inspiring better performance (Bass & Riggio, 2006). The construct of empowerment has also been noted by Kelley (1998) as an outcome of transformational leadership. According to Conger and Kanungo (1998), transformational leadership is also connected to empowerment through self-efficacy. It is worth noting that empowerment in a school setting is synonymous with shared school leadership or teacher leadership (Murphy, 2005). Terry (1998) associated empowerment with shared decision making and observed it to translate to teacher leadership. It covers a broad spectrum of concepts, which include teacher involvement in school leadership, granting new respect to teachers and improving their work conditions, higher salaries with new professional structures, teacher revolution to gain control of the profession, and increasing teacher autonomy and professionalism (Blase & Blase, 2001).

An Overview of Power and Empowerment in Schools

The experiences of both teachers and students have been situated within the pervasive structures of domination occurring in American culture and schools (Kreisberg, 1992). One major focus of the reform movements was teacher empowerment, which is an auxiliary of transformational leadership. It was lauded as part of the solution to the plethora of problems plaguing the school systems. The traditional top-down management style long practiced in school systems was found wanting (Kreisberg, 1992). As a result, many voices in the education arena championed the cause for site-based leadership and for participative leadership or management as opposed to centralized management.

In earlier literature on educational leadership, little attention was given to the teacher as an educational leader in the school other than in the classroom (Brownlee, 1979). As Lynch and Strodl (1991) posited, the assumption was that teaching is for teachers and leadership is for the administrators and managers of schools. While the need for leadership has been the central ingredient in the school change and improvement literature, historically that leadership has been associated with those roles with positional authority over teachers (Conley, Marks, & Smylie, as cited in Murphy, 2005; Firestone & Heller, 1995; Jantzi, Leithwood, Ryan, & Steichbach, 1999). In general, teachers found themselves in a paradoxical place in the web of institutional and ideological domination in schools. Despite the fact that teachers are central figures of authority and control in the classrooms, in the larger hierarchy of educational bureaucracy, they are often isolated and notably powerless (Kreisberg, 1992). However, the empowerment of teachers has become an important component in the drive for educational reform initiatives that embrace greater teacher capacity and empowerment through shared leadership models (Short, 1994).

There are remarkable benefits that stem from teacher empowerment (Pounder & Short, 1998). For instance, the teachers' commitment to the school as an organization has been found to predict its effectiveness and positive outcomes (Howell & Dorfman, 1986; Rosenholtz, 1991). It has been inversely correlated with teacher turnover (Bogler & Somech, 2004).

This researcher concurred with Crowther and Olsen (1997) that the theme of teacher leadership remains a seriously underdeveloped topic. This shortfall augments the reasons and need for further empirical exploration of teacher empowerment or teacher

leadership as a construct that is essential to change and improvement in a school (Whitaker, 1995).

If the focus is confined to the milieu of Christian schools, Christian leadership is a leadership model that is truly transformational and authentically empowering. It is committed to the authority of God and attentive to His voice, His eternal Word. It frames the whole enterprise of teaching and learning within the parameters of God's Word (Schultz, 1998). It is also modeled after the timeless leadership of Jesus Christ. For Christ, true leadership means serving. Greenleaf (2002) echoed this principle when he posited that the leader is servant first. His servant leadership model, which has been popular both in Christian and secular corporate settings, agrees with Matt. 23:11-12 (New King James Version): "He who is greatest among you shall be your servant. And whoever exalts himself shall be humbled, and he who humbles himself shall be exalted." Servant leaders look at leadership as an act of service (Blanchard & Hodges, 2003). In addition, the most important choice a leader makes is the choice to serve, without which one's capacity to lead is severely limited (Greenleaf, 2002). Thus, the principle of servant leadership is the embodiment of transforming Christian leadership in Christian schools.

Transformational Leadership and Teacher Empowerment in Christian Schools

The K-12 educational leaders in the United States have, over the past few decades, faced a barrage of criticism about their leadership practices and have also been called upon to institute educational reforms (Chubb & More; Guthrie, Hill, & Pierce, cited in Boyatt, Chang-Ho, Ji, Shee, & Soon-Chiew, 2002). It is important to explain that K-12 Christian schools have not been immune to those leadership concerns faced by public schools (Shee et al., 2002). This fact has created the need for Christian leaders to

undertake leadership reforms that are consistent with the dictates of transformational leadership. This, in essence, calls for teachers' empowerment. It is essential, as Braggs (2008) observed, for leaders of Christian schools bent on perfecting their leadership skills to understand the lexicon of transformational leadership and how it aligns with their values, beliefs, and practices.

Teacher empowerment is translated to mean shared school/teacher leadership (Blase & Blase, 2001). However, as noted in the above literature, there has been little documentation about empowerment and organizational commitment of teachers in Christian schools despite the fact that empowerment has become a major outcome of transformational leadership. In his doctoral research at Liberty University, Braggs (2008) looked at transformational leadership practices in Christian schools in two distinct regions of the United States, the Southeast and the Mid-Atlantic North. Although not conclusively supported by data at 0.05 alpha levels, he found that the biblical culture (of the Bible belt) instilled a great many attributes of transformational leadership.

Transformational leadership has not been studied within the domain of K-12 Christian schools but has been studied in churches and Christian colleges (Braggs, 2008). In a secular setting, a study by Keiser and Shen (2000) drew a sample of teachers only from public schools and found a disparity in principals' and teachers' perceptions of teacher empowerment. In his dissertation on the leadership of the Assemblies of God denomination headquarters, Miller (2003) found the most successful administrators also demonstrated high attributes of transformational leadership. In another doctoral study centered on the church, Knudsen (2006) found that leaders practicing transformational leadership had a greater impact on their followers than those who were non-

transformational. In a case study attributed to a Christian college leader, Mumm (2005) found that transformational leadership helped develop followers and also fostered their enthusiasm. There is little documentation regarding what is occurring in Christian schools on the topic of transformational leadership. This lack enhanced the need to pursue research studies within the confines of Christian schools and this research was an attempt to address the apparent empirical need. It is imperative to look at leadership practices in Christian schools in order to gauge their educational effectiveness in relation to teacher empowerment and its implications for leadership.

Leadership: A Christian Perspective

Before embarking on the main conceptual constructs of this study, it is imperative to look at what constitutes the milieu from which the study is drawn. This milieu is leadership. If there was ever a moment in history when a comprehensive strategic view of leadership was needed in every facet of life, it is now (Bennis & Nanus, 2003). The topic of leadership is in fashion, as can be deciphered from society's preoccupation with it and also the massive volume of literature which has emerged in the area (Rosenbach & Taylor, 1998). In spite of the fact that leadership has been widely studied throughout the 20th century, the current explosion of interest in leadership--especially the great effort to find, create, foster, train, and develop more of it--reflects the important features of the historic moment (Bass, 1981; Fleet, Van, & Yukl, 1989).

As postulated by Burns (2003), leadership is an expanding field of study that may join the ranks of disciplines such as history, philosophy, and other social sciences in recognition. Currently, however, leadership remains in the growing stages and has yet to institute a unifying theory for scholars (Bennis & Nanus, 2003). Therefore, the

understanding of leadership remains largely elusive. In this vein, Bennis and Nanus (2003) remarked that leadership is the most studied and least understood topic of any in the social sciences.

There are equally as many definitions of leadership as there are people attempting to define it (Rosenbach & Taylor, 1998). Despite the fact that studies do not agree on what leadership is, a consensus is emerging around the embodiment of effective leadership at this time in history, namely the paramount need to provide vision around which members of an organization can unite and direct their energies productively (Rosenbach & Taylor, 1998). Leadership requires vision, and this vision is the force that provides purposeful energy to the work of an organization (Southwest Educational Development Laboratory, 2005).

In order to actively bring changes to an organization, leaders must be able to make decisions about the future state (Manasse, 1986). Manasse (1986) enunciated that leaders begin with a personal vision that fosters a shared vision with their coworkers or followers, and their communication of the vision empowers others to act. This is the embodiment of transformational leadership. According to Westley and Mintzberg (1989), visionary or transformational leadership is dynamic and involves a three-stage process: (a) an image of the desired future for the organization (vision), which is (b) communicated or shared and (c) serves to empower those followers so that they can enact the vision. This element of vision, coupled with attributes of charisma, inspiration, and intellectual stimulation, constitutes transformational leadership (Bass, 1985). However, it should be noted that a vision without action is worthless, and that is why successful

leaders are bent on energizing their followers to work toward common causes (Rosenbach & Taylor, 1998).

Although secular principles may provide fundamentals of effective leadership, Quicke (2006) sternly warned of the danger of being so absorbed in the pursuit of success and blindly embracing secular leadership principles and practice. Henry and Michael Blackaby protested the developing trend among many Christian leaders to adopt an almost indiscriminate and uncritical acceptance of secular leadership theory without measuring it against timeless precepts (as cited in Quicke, 2006). The talk about God and spirituality are put aside by pragmatism in leadership when secular models exert a hypnotic control of the church (Quicke, 2006).

Visionary Christian Leadership

The need for the leader to be visionary is also echoed in the Bible. Without a vision people perish (Prov. 28:18, New International Version). In their definition of leadership, Branks and Ledbetter (2004) observed leadership to involve a person, group, or organization that shows the way in an area of life, whether in the short or the long term, and in doing so both influences and empowers enough people to bring about change in that area. From a Christian point of view, it is only when the direction and the method are in line with God's purposes, character, and ways of operating that godly leadership takes place (Quicke, 2006). Further, a Christian leader is someone who is called by God to lead and to possess virtuous character. The Christian leader effectively motivates, mobilizes resources, and directs people toward the fulfillment of a jointly embraced vision of God (Barna, 1998). Christian leadership was also associated with articulation

of God's kingdom and effectively defining and communicating its incarnation, following Christ's example of service (Williams & McKibben, 1994).

The need for leaders to empower others has also been delineated by Maxwell (2007). Maxwell (2007) explained that good leaders go to their people, connect, find common ground, and empower them to succeed. He also observed that, in some ways, leaders have less freedom as they move up the organizational structure. Maxwell (2007) further attributed leadership to the influence impacted on others. Maxwell (2007) also observed that leading well is not about enriching oneself, but empowering others. Greenleaf (2002) concurred with this principle, as he posited that a great leader is seen as a servant first, and that simple fact is the key to his greatness. In Matt. 23:11, Jesus expounded this salient principle of servanthood in leadership when he taught his followers that the greatest among them shall be the servant of all. Packard indicated it was seen as an art of getting others to want to do something that you are convinced should be done (as cited in Kouzes & Posner, 2002). It is a dynamic process in which a man or woman, with God-given capacity, influences a specific group of God's people toward his purposes for that group (Clinton, 1988).

A Christian leader is a person of integrity who is generative and compassionate and who communicates hope and joy (Maxwell, 2007). A Christian leader listens to people; creates a vision with those people; responds to the needs of the Christian community, especially the marginalized; works collaboratively with others in responding to those needs; expands the concept of ministry; and supports the gifts and ministries of the laity and those who influence their values (Sofield, 1995).

Leadership and Teacher Empowerment in General School Context

The publication of *A Nation at Risk* in 1983 by the National Commission on Excellence in Education ushered in a national educational reform movement. Coupled with a rich array of reports, this movement called for massive changes to help schools achieve educational excellence (as cited in Blase & Blase, 2001). By the end of the decade, Glickman (1989) and others popularized the notion that teachers should be seen as a solution to educational problems, not the source of the problem. This movement was the embodiment of the second wave of educational reform and restructuring, which placed emphasis on teacher empowerment, active involvement of teachers in decision making, and shared governance (Blase & Blase, 2001).

The current efforts in the United States to restructure schools emphasize new types of leadership and teacher empowerment (Blase & Blase, 2001). In fact, empowerment has been observed as the topic of the day (Ford & Fottler, 1995). Teacher empowerment has been an important topic even in the legislative arena where the Teacher Empowerment Act was fervently debated in the 106th Congress of the United States.

The participation by teachers in school leadership affairs began to take root in the 1980s. This participation was a clear departure from what had traditionally been the norm (Edwards, Green, & Lyons, 2002). Since the recommendation from the Carnegie Forum on Education Reform and the Economy (1986) that teachers be given a greater voice in the decisions that affect the school, the term *teacher empowerment* has been one of the most recurrent buzzwords in school educational circles. Empowerment has been noted by Owens (2004) as a resource for providing opportunities for teachers to participate

actively, openly, and without fear in the endless process of shaping and molding the vision of the school and its culture through iterative discussion. Further, when this happens, Burns (1978) observed three things that are essential to transforming leadership:

1. Teachers participate actively in the dynamic ongoing process of leadership by contributing their knowledge, insights, and ideas to the development of the vision of the school.
2. Teachers acquire greater personal ownership, and thus a greater sense of personal commitment to the values for which the school stands and that shape its vision for the future.
3. By their engagement in the process, and being personally committed to its outcomes, teachers are stimulated to increase their awareness of both the larger mission of the school and their own daily mundane work toward the achievement of that mission.

Owens (2004) postulated that rather than manipulating followers, leadership taps the motivation of teachers (their aspirations, beliefs, and values) and enriches the significance of what they do by better connecting their daily work to the larger mission of the enterprise. Owens (2004) concluded that transforming leadership empowers teachers. Empowerment of teachers serves as a desirable component of school improvement, and the spectrum of benefits should not be underestimated.

Further Delineation of Empowerment in Corporate and Educational Settings

In order to discuss empowerment, it helps to understand what the term encompasses. The definitions of empowerment have largely emanated from the corporate world, but it is important to note that the concept of teacher empowerment parallels

employee empowerment in business. The interest in empowerment in education has sprung from business and industrial efforts to improve productivity (Short, 1994).

Empowerment occurs when power goes to employees, who then experience a sense of ownership and control over their jobs (Byham, Wellins, & Wilson, 1991). Byham and Cox (1992) stated that empowering employees involves helping them take ownership and control of their jobs so that they take personal interest in improving the performance of the organization. According to McKenna (1990), empowerment is a building of personal self-esteem and possibly the motivation for the worker to further her training and education. Wellins et al. (1991) indicated that an organization empowers its employees when it enables them to take on more responsibility and make use of what they know and can learn. Terry (1998) observed that a more empowered workforce is a more productive workforce.

Benefits of Teacher Empowerment

Empowered teachers have the autonomy to make or influence decisions about curriculum, pedagogy, and assessment (Wasley, 1991). McCarty (1993) made the observation that empowered teachers are likely to become risk takers by experimenting with new ideas, reading new books, and attending and planning professional development activities in order to survive and thrive in the current high-stakes school climate. Empowered teachers also embrace new roles such as action researcher, team leader, curriculum developer, and in-house trainer (Boles & Troen, 1992).

As noted above, empowerment encourages teachers to take risks as well as embrace new roles. These actions should prompt school administrators to devise new ways of doing things that empower teachers. One way administrators empower teachers

is to provide them the freedom to change schedules and staffing and to assign students' activities (Wasley, 1991). In addition, administrators need to harness structures for school governance that foster teacher participation in the decision- and policy-making activities of the school (Marzano, 2003). This change may include usage of new meeting formats, one example being faculty-based meetings where issues and topics of concern are prioritized and addressed accordingly. This modification affords teachers the opportunity to become more engaged in the decision-making process (Simpson, 1990).

The best argument for teacher empowerment is the benefits it provides students because "it promises to yield better decisions and better results" (Schlechty, 1990, p. 52). Sarason (1971) further added that empowered teachers assume more responsibility as a result of their involvement in the school's decision-making process and their morale improves, while better solutions to school and leadership problems will be generated.

"In any attempt to improve education, teachers are central" (Frymier, 1987, p. 9). In Murphy and Evertson's (1990) restructuring paradigm, empowerment is included as an integral part of reform. In the same vein, "Teacher empowerment is the opportunity and confidence to act upon one's ideas and to influence the way one performs in one's profession" (Melenyzer, 1990, p. 4). Byham and Cox (1992) postulated that empowerment helps employees take a personal interest in improving the organization. The construct of empowerment holds promise for improving the educational setting for both teachers and students. Maeroff (1988) believed that the term *empowerment* is congruent with professionalism.

Participative Management

Alienation at work was cited as the most pervasive phenomenon of the post-industrial society, and management in both the private and public sectors are engaged in a constant struggle against alienation (Kanungo, 1992). Alienated workers were observed to be apathetic, frustrated, and uninvolved with their jobs (Short, 1994). Businesses or institutions that counter worker alienation with empowerment plans improve their position to compete with firms who have solved the problem. The principal strategy is to replace authority-based management with participative management.

Teacher leadership

In the realm of education, teacher empowerment can be defined as “investing teachers with the right to participate in the determination of school goals and policies and to exercise professional judgment about what and how to teach” (Borin, 1989, p. 82). Empowerment is referred to as shared decision-making and observed to be essential to school reform and to the changing demands in a global world (Terry, 1998). Empowerment translates to teacher leadership and exemplifies a paradigm shift with the decisions made by those working more closely with the students rather than those at the top of the pyramid (Terry, 1998).

Professionalism

Further, teacher empowerment has been defined as a function of the readiness of building-level administrators to share autonomy with those whose commitment is necessary to make the educational program function at the highest level of efficiency (Brown, Lucas, & Markus, 1991). Lee (1991) shared this posture by defining teacher empowerment as the development of an environment in which teachers act like

professionals and are treated as professionals. He further explained that empowerment means that school leaders provide teachers with the authority to make decisions that have, in traditional systems, been made for them; a time and place to work and plan together during the school day; and a voice in efforts to deepen their knowledge and improve teaching. The most effective leaders are those whose teachers have ownership in the mission of the school and a vital interest in its effectiveness. Short (1994) and Lucas et al. (1991) stated that the more that is given away, the more powerful leaders become; leaders who create leaders are more powerful than those who do not.

Improvement

Empowerment was perceived as a process whereby school participants improve in their competence to take charge of their own growth and resolve their own problems (Short, 1994). Short (1994) also alluded to the fact that empowered individuals believe they have the skills and knowledge to act on a situation and improve it. Short (1994) further argued that empowered schools and teachers are organizations and individuals that create opportunities for competence to be developed and displayed. Empowerment was observed to consist of “enabling experience provided within an organization that fosters autonomy, choice, control, and responsibility” (Short & Rinehart, 1992a, p. 952).

Decision making

Empowerment also was described in terms of participatory decision making (Louis & Marks, 1997). Louis and Marks (1997) posited that participatory decision making fosters workers’ knowledge, reduces worker isolation, and increases workers’ sense of the whole picture. Empowerment, they noted, transforms the workplace. The modern and contemporary educational trends have infused empowerment strategies as

tools to improve school effectiveness. The principle, notes Short (1994), is that those who are closest to teaching should be making decisions about teaching and other salient issues. Short (1994) stated that terms such as *site-based management*, *teacher empowerment*, and *local control* have filled the literature as industrial models have been adapted to educational settings.

Responsibility and liberty

The concept of empowerment has been described as a construct that ties personal competencies and abilities to environments that provide opportunities for choice and autonomy in demonstrating those competencies (Rappaport, 1987; Zimmerman & Rappaport, 1988). The first of two main issues attributed to empowerment by Dunst (1991) is enabling experiences, provided within an organization that fosters autonomy, choice, control, and responsibility. The second issue identified is the individual liberty to display existing competencies as well as learn new competencies that support and strengthen functioning (Dunst, 1999).

Teamwork

Empowerment is not, however, confined to teachers alone. One of the components of school restructuring is the empowerment of teachers, administrators, and students (Murphy & Evertson, 1990; Short, et al., 1991). Empowerment was noted by Greer, Melvin, and Short (1994) to encompass an overall school philosophy of teamwork, collegiality, participation in decision making, and problem solving without the constraints of a bureaucratic organization. Short and Rinehart (1992a) postulated that empowerment encompasses other dimensions, such as teacher perceptions of status, self-efficacy, autonomy, teacher impact, and opportunities for professional growth.

Value

Shared decision making relates to the participation of teachers in critical decisions that directly affect their work, as observed by Short and Rinehart (1992a). They further observed that providing teachers with a significant role in school decision making is a key element in empowerment in that teachers gain the opportunity to increase control over their work environment.

Impact

Ashton and Webb (1986) observed that when teachers know that their actions have an impact on school life the sense of self-worth increases. Lightfoot (1986) study further posited that teachers' self esteem was generated from the respect they received from the school community that stemmed from their accomplishments.

Self-efficacy

Ashton and Webb (1986) reported that teacher self-esteem grows when they feel that they are doing something worthwhile, that they are doing it in a competent manner, and that they are recognized for their accomplishments. Terry (1998) observed that recognition of this esteem was found in comments and attitudes from the various constituents of the school environment, responses to the teacher's instructions, and the respect afforded the teaching profession.

Support and Status

In her study of good schools, Lightfoot (1986) added that teachers achieved growth from the respect they received from parents and community as well as the support they felt for their ideas. Status refers to the teacher's sense of self-esteem ascribed by

students, parents, community members, peers, and superiors to the position of the teacher.

Autonomy

Autonomy affords teachers with opportunity to map out certain aspects of their work life, which may include control over scheduling, curriculum, textbooks, and instructional planning (Short, 1994). It allows teachers to gain ownership of the aforementioned aspects of school life.

Professional growth

Traditionally, principal leadership has been looked upon as authoritarian and has evolved into a type of leadership that can be described as coercive, manipulative, and controlling (Murphy, 2005). These negative tactics have been proven to be counter-productive. The principal has been described as a change agent who is instrumental in fostering faculty empowerment and teacher leadership. It is imperative that the principal creates an environment conducive to empowerment, demonstrates ideals, encourages all endeavors toward empowerment, and applauds all empowerment success (Terry, 1998).

With the understanding of what empowerment has done for some teachers, it is essential that teachers nationwide experience the same opportunities firsthand: the growth and development that empowerment provides (Erlandson & Bifano, 1987). Empowering teachers as leaders has been seen as a way of putting teachers at the center of the reform movement, to keep good teachers in education, to entice new teachers into the profession, and to reverse a general trend toward treating them as employees who do specific tasks planned in detail by other people (Terry, 1998).

Inner Leadership Qualities

Covey (1989) suggested that a leader must begin with “self” to become effective. He suggested that the more aware one is of personal paradigms, the more likely one can take responsibility for his own paradigms. A paradigm is defined as the way one perceives, understands, and interprets everything going on. Covey (1989) believed one needs to examine one’s paradigms against reality, listen, and be open to other people’s perceptions. Covey further stated that one’s character is a composite of his habits and, through tremendous commitment; these habits can be changed to bring about success. He defined habit as “the intersection of knowledge, skill, and desire” (Covey, 1989, p. 23). Knowledge is what to do and why. Skill is how to do it. Desire is the motivation and the want to do. In order to develop a habit, all three have to be incorporated. Covey (1989) articulated the seven habits of highly effective people and suggested that all seven habits must be developed and continuously practiced. The seven habits are: be proactive, begin with the end in mind, put first things first, think win-win, seek first to understand and then to be understood, synergize, and sharpen the saw. Self-awareness, an in-depth study of self, serves as the basis for the seven habits.

Bennis and Nanus (2003) promoted similar strategies for empowerment that interrelate to Covey’s habits. The leader must possess the innate ability to have vision. A vision, observed Bennis and Nanus (2003), refers to the future state that does not presently exist. They also noted that a leader operates on a vision that is based on values, commitment, and aspirations. Good leaders foster good interaction with other people. They also employ effective communication that embraces a lot of listening and asking questions. Two-way communication is established in order to gain access to these ideas

(Bennis & Nanus, 2003). There are three sources from which people seek guidance: the past, present, and alternate image of future possibilities. Reflection helps in determining what did or did not work. A vision cannot be implemented by edict or by coercion but by an act of persuasion, of creating an enthusiastic and dedicated commitment to the vision. There is an agreed upon assumption that the vision is right for the organization and the people who are working in it (Bennis & Nanus, 2003).

Kouzes and Posner (2002) stated that the best leaders lead by example. The intensity, vigor, and passion of a leader's commitment to his or her true values determine how seriously he or she is taken. Constituents pay more attention to the values that leaders use than to the values they say they believe. What constituents see is the tangible evidence that people are true to their beliefs through their actions (Kouzes & Posner, 2002). Thus, the true leader develops credibility. It is worth noting that, in empowerment, principals do not have to relinquish power and teachers do not have to challenge authority. Rather, empowerment should be seen as a form of teacher liberation, meaning that the teacher is free from the "unwarranted control of unjustified beliefs" (Prawat, 1991, p. 749).

Leadership is necessary to help organizations develop a vision of what they can be, then mobilize the organization to change toward that vision (Terry, 1998). The context of leadership involves commitment and credibility (Foster, 1986). Terry (1998) added that it also involves a radical change in thinking to achieve leadership effectiveness. He further posited that the vision of empowerment exemplifies a paradigm shift, with the decisions being made by those working closely with students, rather than by those at the top of the pyramid. This pyramid must be reversed, with the decision

making occurring at the bottom. The argument can be made that, in this new model, the roles of principals and teachers as leaders are greatly expanded.

The Need for Organizational Commitment

Mowday et al. (1979) defined organizational commitment as “the relative strength of an individual’s identification with and involvement in a particular organization” (p. 226). Organizational commitment is based on the acceptance of the organization’s goals and values (identification), the willingness to invest effort in behalf of the organization (involvement), and the importance attached to keeping up the membership in the organization (loyalty). These characteristics imply that the members of the organization who wish to be active players in the organization have an impact on what is going on, feel that they have high status within it, and are ready to contribute beyond what is expected of them (Bogler & Somech, 2004). This is especially true when the leaders of the organization are perceived as adopting consultative or participative leadership behavior where shared decision making is prevalent (Yousef, 2000).

In a number of studies reviewed by Firestone and Pennel (1993), teachers’ autonomy in making classroom decisions, their participation in school-wide decision making, and their opportunities to learn were among the organizational conditions that showed a strong association with teachers commitment to the organization (Bogler & Somech, 2004). A positive relationship was also found between organizational commitment and job involvement (Blau & Boal, 1989).

In surveys taken across America concerning the non-managerial work force, a considerable gap exists between the hours people are paid for working versus the actual number of hours spent productively. Approximately 75% of those surveyed admitted that

they could be more effective (Kanungo, 1992). The lack of leadership empowering the work force has been cited as the number one reason for this situation (Blase, 1990). Similarly, leadership problems riddle and plague the educational system. Since the current methods of educational leadership have been considered ineffective (Peel & Walker, 1994), teacher empowerment resulting in teacher leadership is foundational to proposals for restructuring schools in the 21st century.

The principal is referred to as the one who must draw on the strengths of teachers if changes are to prevail (National Association of Secondary School Principals [NASSP], 1996). The principal fosters an atmosphere that encourages teachers to take risks to meet the needs of students. In addition, teachers are called upon to provide the leadership essential to the success of reform (NASSP, 1996).

The Need for Professional Commitment (Job Involvement)

The construct of job involvement is defined as "psychological identification with a job" (Kanungo, 1982, p. 97). The implication of this definition is that a job-involved person sees his job "as an important part of his self-concept" (Lawler & Hall, 1970, p. 311), and that jobs "define one's self-concept in a major way" (Kanungo, 1982, p. 82). There are many organizational benefits associated with job involvement. The most well-documented sequelae of job involvement is job satisfaction (Baba & Jamal, 1991; Elloy, Everett, & Flynn, 1991; Gerpott, 1990; Mathieu & Farr, 1991; Newton, Shore, & Thornton, 1990; Paterson & O'Driscoll, 1990). This list is not exhaustive as there are other attitudes and behaviors that have also been linked to job involvement.

The Need for Job Satisfaction

Job satisfaction has been defined as being satisfied not only with one's job, but also with one's career in general (Heesbeen, Benneker, & Boer, 2008). Job satisfaction is one of the most widely studied areas in the field of occupational and industrial psychology (Rahman & Sen, 1987). Rahman and Sen (1987) further observed that the interest in job satisfaction is largely influenced by the view that it has direct impact on employee health and wellbeing. The focus on job satisfaction has also been impacted by the contention that satisfied employees perform at higher levels; however, there is some debate as to whether job satisfaction causes productivity or productivity causes job satisfaction (Iaffaldano & Muchinsky, 1985; Petty, McGee & Cavender, 1984). Research on job satisfaction started to develop when Hoppock conceptualized a definition as any combination of psychological, physiological, and environmental circumstances that cause a person to be satisfied with his/her job (as cited in Rinehart & Short, 1994). Since that time, the effects of job satisfaction for organizations and for employees have been extensively investigated.

In the field of education, for example, Lester (1988) reviewed the literature for the years 1975 through 1986 and found 1063 articles concerning job satisfaction and teaching. Studies have found a significant correlation between teacher empowerment and job satisfaction (Rinehart & Short, 1994). Research by Rinehart and Short (1994) revealed a positive correlation between empowerment and job satisfaction. They posited that to increase job satisfaction among teachers, school administrators and policy makers should develop management structures that enhance teacher empowerment. Other studies have made attempts to link job satisfaction with variables such as gender,

absenteeism, and the work environment (Bridges, 1980; Cano & Miller, 1992; Conley, Bacharach, & Bauer, 1989, as cited in Rinehart & Short, 1994).

Leadership and Power

Covey (1989) interpreted the literary materials that have flooded the leadership professions. He noted that the preceding 50 years of published advice focused on supervision. It included methods involving “personality growth, communication, skill training, and education in the field of influence, strategies, and positive thinking” (Covey, 1989, p. 34). He regarded the so called “human relation techniques” as manipulative. The way leaders interact and communicate with their followers is crucial. He noted that what is communicated is far more powerful than anything we say or do (Covey, 1990).

“Leadership is the wise use of power” (Bennis, 1989, p. 184). Traditionally, however, principals have not demonstrated wise use of power (Reitzug, 1991). Reitzug (1991) further posited that principals do not always tell their subordinates how to act. Teachers are left with little voice in the workplace over matters such as the choice of curriculum material, types of tests used to evaluate instruction, the scheduling of classes, and the allocation of instructional resources. A lack of autonomy and control on the part of the teachers has been problematic because it affects productivity and commitment to the workplace and ultimately affects their teacher leadership capabilities (Reitzug, 1991).

Control tactics may produce people who have outward success but are miserable internally because of the conflicts they create to reach success. Too often people depend on others, which leads to destructive relationships. The conflicts result due to perceptions people develop over time within their personal experiences. Perceptions influence the way one interprets things and how one reacts. People, unfortunately, tend to assume that

their perception of a situation is the only way and that everyone sees it the same way. Attitudes and behaviors grow out of these assumptions. Yet others see things differently from their own point of view. “Where we stand depends on where we sit” (Covey, 1989, p. 22). Covey’s analysis summarizes the underlying causes for ineffective leadership as it exists in education.

Negative Principal Practices

In a research study conducted by Michigan State University, Blase (1990) found that 92% of teachers surveyed indicated that their morale was substantially affected by their principal’s tactics. Terms such as “apathetic, alienated, and less satisfied” were used (Blase, 1990, p. 731). In addition, teacher involvement in school-wide activities was reduced substantially. The study also observed that the teachers’ low self-esteem was attributed to the fact the principal made them feel as if their thoughts and opinions were not valid or important. Feelings of teachers included anger, depression, and anxiety. The study concluded that all of these morale and self-esteem factors impelled teacher input and leadership. The same study that examined politics in the educational setting found those administrators were not revered as respected, caring, or popular people by those they led and managed. An overview of the data indicated that a majority of principals used control tactics (Blase, 1990). These school principals were seen as manipulators. Rewards were associated with resource distribution, administrative assignments, appointments, and advancement opportunities (Blase, 1990).

Further in-depth investigation of politics within the school revealed that control tactics were seen as deceptive and self-serving (Blase, 1990). The control tactics were experienced as coercive and were defined as forceful, stressful, and punishing. They were

also perceived as reactive and unilateral. The path of the influence was from the principals to teachers, and the end goals were seen as predetermined and nonnegotiable. The manipulation of merit salaries, evaluations, and work contracts were discussed less frequently. Teachers also claimed that some principals used threats of sanctions to obtain compliance. Likewise, principals were seen as manipulative regarding favored teachers. Those teachers who went along with the politics reaped the benefits.

Some principals used harassment as a control tactic (Blase, 1990). Such a strategy was used to force teachers to leave. Principals created pseudo-opportunities for teacher participation, leadership, and decision making. Frequently principals “employed the subordinate status, emphasizing the authority difference: I am the boss, you are here to do a certain job” (Blase, 1990, p. 740).

Principals were perceived as using this tactic to reduce the vulnerability they could otherwise experience from criticism and demands from both external and internal publics. Acquiescence involves submissive behavior, which tends to direct decision making to please the community, even when it is against sound educational standards. People with money used their influence to get something for their child. Ingratiation included the promotion of activities and programs to satisfy the community even when it was nonsensical. Inconsistency referred to the contradictory changes in day-to-day decisions and policies in response to conflicting external pressures. External pressures many times included the superintendent and board members (Blase, 1990).

Chapter Summary

In conclusion, empowerment is a dominant theme in all types of organizations, including business, industry, education, and service organizations. Current interest in empowerment has filtered to school organizations and school participants (Lightfoot, 1986; Maeroff, 1988). Teacher leadership, which is the embodiment of empowerment, has gained and continues to gain much attention with the current push for school improvement. The pressure to raise student performance on standardized tests is increasing. This, coupled with a growing teacher shortage and the need to retain qualified teaching professionals, adds to the demand for improved leadership in schools (Lightfoot, 1986; Maeroff, 1988). Researchers as well as educational, political, and other public groups have advocated the restructuring of public education and the empowerment of school staff members (Frymier, 1987; Maeroff, 1988). The object of this study was to explore the construct of teacher empowerment as an outcome of transformational leadership and its associations with personal and organizational outcomes relating to K-12 Christian school principals and leaders in the south central and northwestern regions of the United States.

CHAPTER THREE: METHODOLOGY

This chapter presents the methodologies used to investigate the hypotheses of the present study. It contains the following subsections: introduction, research design, participants, settings, instruments, procedures, and data analysis.

Introduction

The present study investigated the construct of perceived teacher empowerment and its influence on teachers' commitment to their schools, their profession, and their job satisfaction. It sought to investigate what dimensions of teacher empowerment (autonomy, decision making, impact, self-efficacy, and professional growth) can best predict the aforementioned variables. Finally, the study sought to examine any disparity between school leaders' and teachers' perceptions of teacher empowerment. The following research questions and hypotheses guided the empirical investigation:

Restatement of Research Questions

1. What are the perceptions of K-12 Christian school teachers regarding teacher empowerment?
2. What are the effects of perceived empowerment on teachers' job satisfaction and commitment to both their schools and the teaching profession?
3. Does a teacher's , gender, level of education, years of educational experience, school type, and school size affect his or her perceptions regarding teacher empowerment?
4. What dimensions of perceived teacher empowerment (autonomy, decision- making, impact, professional growth, self-efficacy, and status)

can best predict teachers' commitment to their schools and their profession, and their job satisfaction?

5. Is there a significant difference between teachers' and principals' perceptions of teacher empowerment?

Restatement of the Hypotheses

The following null hypotheses and sub-hypotheses were formulated to test the research variables noted above.

Hypothesis 1

H₀1₁ There is no significant level of perceived teacher empowerment related to decision-making as measured by School Participant Empowerment Scale (SPES).

H₀1₂ There is no significant level of perceived teacher empowerment related to autonomy as measured by School Participant Empowerment Scale (SPES).

H₀1₃ There is no significant level of perceived teacher empowerment related to professional growth as measured by School Participant Empowerment Scale (SPES).

H₀1₄ There is no significant level of perceived teacher empowerment related to impact as measured by School Participant Empowerment Scale (SPES).

H₀1₅ There is no significant level of perceived teacher empowerment related to status as measured by School Participant Empowerment Scale (SPES).

H₀₁₆ There is no significant level of perceived teacher empowerment related to self-efficacy as measured by School Participant Empowerment Scale (SPES).

Hypothesis 2

The perception of empowerment of K-12 Christian school teachers has no significant correlation with their commitment to their schools and their profession, and their job satisfaction as measured by Michigan Organizational Assessment Questionnaire-Job Satisfaction Subscale (MOAQ-JSS), Organizational Commitment Questionnaire (OCQ), and the Job Involvement Questionnaire (JIQ).

H₀₂₁ The perception of empowerment of K-12 Christian school teachers has no significant correlation with commitment to their schools.

H₀₂₂ The perception of empowerment of K-12 Christian school teachers has no significant correlation with commitment to their profession.

H₀₂₃ The perception of empowerment of K-12 Christian school teachers has no significant correlation with their job satisfaction.

Hypothesis 3

The K-12 school teacher's gender, level of education, school type, and school size have no significant effect on perception of their empowerment as measured by School Participant Empowerment Scale (SPES).

H₀₃₁ Gender does not have a significant effect on a teacher's perception of their empowerment.

H₀₃₂ Level of education does not have a significant effect on a teacher's

perception of their teacher empowerment.

H₀₃₃ School type does not have a significant effect on a teacher's perception of their empowerment.

H₀₃₄ Size of school does not have a significant effect on a teacher's perception of their empowerment.

Hypothesis number 4

The teacher's perceived empowerment dimensions of autonomy, decision making, impact, professional growth, self-efficacy, and status are not significant predictors of their organizational commitment, professional commitment, and job satisfaction as measured by School Participant Empowerment Scale (SPES), Organizational Commitment Questionnaire (OCQ), Job Involvement Questionnaire (JIQ) (Professional Commitment), and Michigan Organizational Assessment Questionnaire Job Satisfaction Subscale (MOAQ-JSS).

H₀₄₁ The teachers' perceived empowerment dimension of autonomy is not a significant predictor of their organizational commitment.

H₀₄₂ The teachers' perceived empowerment dimension of autonomy is not a significant predictor of their professional commitment.

H₀₄₃ The teachers' perceived empowerment dimension of autonomy is not a significant predictor of their job satisfaction.

H₀₄₄ The teachers' perceived empowerment dimension of decision making is not a significant predictor of their organizational commitment.

- H₀₄₅ The teachers' perceived empowerment dimension of decision making is not a significant predictor of their professional commitment.
- H₀₄₆ The teachers' perceived empowerment dimension of decision making is not a significant predictor of their job satisfaction.
- H₀₄₇ The teachers' perceived empowerment dimension of impact is not a significant predictor of their organizational commitment.
- H₀₄₈ The teachers' perceived empowerment dimension of impact is not a significant predictor of their professional commitment.
- H₀₄₉ The teachers' perceived empowerment dimension of impact is not a significant predictor of their job satisfaction.
- H₀₄₁₀ The teachers' perceived empowerment dimension of professional growth is not a significant predictor of their organizational commitment.
- H₀₄₁₁ The teachers' perceived empowerment dimension of professional growth is not a significant predictor of their professional commitment.
- H₀₄₁₂ The teachers' perceived empowerment dimension of professional growth is not a significant predictor of their job satisfaction.
- H₀₄₁₃ The teachers' perceived empowerment dimension of self-efficacy is not a significant predictor of their organizational commitment.
- H₀₄₁₄ The teachers' perceived empowerment dimension of self-efficacy is not a significant predictor of their professional commitment.

H₀4₁₅ The teachers' perceived empowerment dimension of self-efficacy is not a significant predictor of their job satisfaction.

H₀4₁₆ The teachers' perceived empowerment dimension of status is not a significant predictor of their organizational commitment.

H₀4₁₇ The teachers' perceived empowerment dimension of status is not a significant predictor of their professional commitment.

H₀4₁₈ The teachers' perceived empowerment dimension of status is not a significant predictor of their job satisfaction.

Hypothesis 5

H₀5 There will be no significant difference in how principals and teachers perceive teacher empowerment as measured by Bolin's Teacher Empowerment Scale.

Research Design

This quantitative study used a combination of causal-comparative and correlational methodologies to test the hypotheses. As the object of the study was to empirically investigate potential relationships by observing preexisting constructs or variables while exploring potential correlational factors, the combined research methodologies were deemed appropriate for the study (Leedy, 1989). The other rationale for opting to use the methods was the high probability of answering research questions under investigation and the fact that they have been used successfully by other researchers (Hager, Scribner, Srichai, & Truell, 2001; Rinehart & Short, 1990; Rinehart & Short, 1992). The casual-comparative research design is the choice for many educational researchers, given the fact that a researcher may not experimentally control

or manipulate variables in an educational setting but is able to investigate situations and relationships in which controlled variation is impossible to introduce (Ary, Jacobs, Razavieh, & Sorensen, 2006).

The items in the set of research instruments used in this study were combined into one online survey that consisted of 78 items and broken down as follows:

Part 1: Demographics had items 1 to 6.

Part 2: School Participant Empowerment Scale (SPES) had items 7 to 44.

Part 3: Organizational Commitment Questionnaire (OCQ) had items 45 to 59.

Part 4: Bolin's Teacher Empowerment Scale had items 60 to 65.

Part 5: Professional Commitment /Job Involvement Questionnaire (JIQ) had items 66 to 75.

Part 6: MOAQ-JSS had items 76 to 78.

These quantitative research questionnaires are explained in greater detail later in the chapter.

The concept of empowerment as a construct of transformational leadership has been broadly studied in the fields of industry, business, and public education, but similar studies are conspicuously lacking in Christian education or the Christian school arena. This researcher undertook this investigative inquiry with the goal of unraveling the phenomena of transformational leadership and teacher empowerment in Christian schools where a thorough review of literature pointed to an empirical void. The lack of research necessitated this quantitative study.

From the viewpoint of a behavioral scientist, statistics are tools that can be used to unravel the mysteries of data collected in research (Shavelson, 1988). Although a

researcher's main interest is in the substance of the study, there is interplay between the substance, the design of the study, and the analysis of the data (Shavelson, 1988). This, in essence, calls for better understanding of the substantive issues under investigation, knowledge of a variety of research designs (along with the logical and statistical rationale underlying them), and selection of the design that is most suited for the substantive issues or phenomenon under scrutiny (Shavelson, 1988).

In designing this study, this author looked at past studies that focused on transformational leadership and empowerment and deduced that quantitative research would be the appropriate research methodology for this study (Ary et al., 2006). Historically, quantitative methodology has dominated educational research; although qualitative research has gained some popularity, the recent trends (including federal initiatives) are swinging the pendulum back in favor of quantitative research (Ary et al., 2006). Quantitative research has its roots in positivism, a philosophic view promulgated in the 19th century (Ary et al., 2006). This philosophy stresses the need for measurement and data gathering using objective techniques and using the data to predict behavior (Ary et al., 2006). As a positivist, this author believes that general principles discovered from research can be applied to predict human behavior and also provide possible solutions to prevailing problems. The quantitative design of this research mirrored Creswell's (2003) conclusion: Quantitative research consists in the collection of data so that information can be quantified and subjected to statistical enquiry in order to accept or refute alternate knowledge claims.

In studying teacher empowerment as a construct of transformational leadership within the province of K-12 Christian schools, this author was aware of the fact that he

came to the scene after the facts. This means that he had no control over the variables as they were already impacted or shaped by factors in the subjects' environment. The obvious choice of research design was, therefore, causal comparative (also referred to as ex-post facto) design. This type of design is used extensively to examine and describe relationships between two or more variables, but it does not examine causal relationships (Shavelson, 1988). The design choice suited this study well as no control or manipulation of variables was needed or possible as is often the case in the field of education (Ary, et al., 2006).

Participants

The population for this study consisted of principals and teachers working in K-12 Christian schools that have active membership with the Association of Christian Schools International (ACSI). The sample consisted of principals and teachers from 200 randomly selected K-12 Christian schools in South Central Region states (Arkansas, Kansas, Louisiana, Missouri, Oklahoma, and Texas) and Northwestern Region states (Alaska, Idaho, Montana, Oregon, and Washington) during the 2009/2010 school year, as geographically designated by ACSI. ACSI records generated a total of 688 schools, with state figures as follows: Texas 264, Washington 93, Oregon 76, Missouri 58, Louisiana 43, Kansas 36, Oklahoma 35, Arkansas 32, Idaho 20, Alaska 18, and Montana 13. For the purpose of this study, a principal is regarded to be the head or the administrator of the school, while a teacher is noted to be a person employed to teach full time in a Christian K-12 school with ACSI affiliation or membership. The selection of these schools from these two regions of the United States was deemed appropriate since it provided a good representative sample of the population relevant to the study.

Settings

It was empirically prudent to study the subjects in naturally occurring groups. The study incorporated 200 K-12 Christian schools from the south central and northwestern regions of the United States. These schools were also active members of the Association of Christian Schools, International (ACSI). ACSI is a Christian organization that serves schools whose mission is to serve Christ by upholding Christian faith and values through education. The school heads and teachers in the selected schools constituted the cluster with characteristics relevant to the variables of the present study. This probability sampling is referred to as cluster sampling (Ary et al., 2006).

Research Instruments

The following research instruments were used to help answer the research questions.

Research Question 1

To help answer research question one and assess the perceptions of K-12 Christian school teachers in the south central and northwestern regions of the United States on teacher empowerment or, in other words, examine whether teachers perceive themselves as empowered, the researcher used a School Participant Empowerment Scale (SPES) developed by Short and Rinehart (1992). This instrument (Appendix A) is a 38-item questionnaire containing six subscales: (a) decision making, (b) professional growth, (c) status, (d) self-efficacy, (e) autonomy, and (f) impact. The response scale is a five-point Likert-type scale, as follows: 1= Strongly Disagree, 2= Disagree, 3= Neutral, 4= Agree and 5= Strongly Agree.

The scale has a reported coefficient alpha of .94 for the total scale and between .81 and .89 for the six-factor scale. The split-half reliability of this instrument is .75

(Short & Rinehart, 1992). The teachers were the independent (status) variable while the perceived level of teacher empowerment was the dependent variable.

Research Question 2

To answer research question two and investigate the effects of perceived teacher empowerment on their job satisfaction and commitment to both their schools and teaching profession, the following instruments were used: Michigan Organizational Assessment Questionnaire Job Satisfaction Subscale (MOAQ-JSS) (Appendix E) (Cammann, Fichman, Henkins, & Klesh, 1979), Organizational Commitment Questionnaire (OCQ) (Appendix B) designed by Mowday et al. (1989), and the Job Involvement Questionnaire (JIQ) designed by Kanungo (1982). JIQ (Appendix D) has shown an inter-item consistency ranging from .74 to .90 (Blau, 1985; Elloy et al., 1991; Kanungo, 1982); discriminant validity against related constructs (Blau, 1985, 1987, 1989; Brooke, Russell, & Price, 1988); and convergent validity with the Lodahl and Kejner (1965) scale and pictorial and semantic-differential measures (Kanungo, 1982).

The Michigan Organizational Assessment Questionnaire Job Satisfaction Subscale (MOAQ-JSS (Appendix E) is a three-item questionnaire and measure of overall job satisfaction. This three-item measure uses a seven-point scale and is rated as follows: 1= strongly disagree, 2= moderately disagree, 3= slightly disagree, 4= neither disagree nor agree, 5= slightly agree, 6= moderately agree, and 7= strongly agree.

A meta-analytic examination of the construct and reliability validity of the Michigan Organizational Assessment Questionnaire Job Satisfaction Subscale determined that the MOAQ-JSS demonstrates acceptable levels of reliability and provides evidence of construct validity based on a pattern of relationships consistent with

that predicted by the nomological network and consistent with past research; continuance commitment was the only job attitude found to be weakly related to the MOAQ-JSS (Bowling & Hammond, 2008). These researchers support the use of the MOAQ-JSS as a construct and face valid measure of global and affective job satisfaction, especially in circumstances where questionnaire length is a concern. The advantages of the MOAQ-JSS include its length (three items) and its focus on the affective component of job satisfaction.

The Organizational Commitment Questionnaire (OCQ) (Appendix B) was first developed by Professor Lyman Porter and later expanded by Mowday et al. (1979). Responses on the OCQ to each item were measured on a seven-point scale with scale point anchors labeled and scored as follows: 1= strongly disagree, 2= moderately disagree, 3= slightly disagree, 4= neither disagree nor agree, 5= slightly agree, 6= moderately agree, and 7= strongly agree. Multiple regressions were used in the statistical analysis. In this question, teacher empowerment was the independent variable, and dependent (outcome) variables were job satisfaction, organizational commitment, and professional commitment.

Research Question 3

To answer research question three and investigate whether a teacher's gender, level of education, years of educational experience, school type, and school size affect his or her perceptions regarding teacher empowerment, the multiple regression statistics were utilized using SPSS software version 17.0. The independent (status) variables were gender, level of education, years of educational experience, school type, and school size. The perception of teacher empowerment was the dependent variable.

Research Question 4

To help answer research question four and investigate what dimensions of perceived teacher empowerment (autonomy, decision making, impact, professional growth, self-efficacy, and status) can best predict teachers' commitment to their schools and profession, and their job satisfaction, the School Participant Empowerment Scale (SPES), Organizational Commitment Questionnaire (OCQ), and Job Involvement Questionnaire (JIQ), and the Michigan Organizational Assessment Questionnaire Job Satisfaction Subscale (MOAQ-JSS) instruments were used. The SPES dimensions are associated with the 38 items, which are grouped as follows:

| | |
|---------------------|--------------------------------|
| Decision making | 17, 13, 19, 25, 30, 35, 37, 38 |
| Professional growth | 2, 8, 14, 20, 26, 31 |
| Status | 3, 9, 15, 21, 27, 34 |
| Self-efficacy | 4, 10, 16, 22, 28, 32 |
| Autonomy | 5, 11, 17, 23 |
| Impact | 6, 12, 18, 24, 29, 36 |

Research Question 5

To answer research question five and investigate whether there is a significant difference between teachers' and principals' perceptions of teacher empowerment, the researcher used a Teacher Empowerment Scale operationalized by Bolin (1989) (Appendix C). It is a self-rating instrument based on a six-point Likert scale and assesses how much influence teachers have in the following six areas: (a) hiring new full-time teachers, (b) evaluating teachers, (c) setting discipline policy, (d) deciding how the budget shall be spent, (e) establishing curriculum, and (f) determining the content of in-

service programs. The six-point Likert scale is scored as follows: 1= No influence, 2= Very little influence, 3= little influence, 4= Moderate influence, 5= much influence, and 6= A great deal of influence. The independent (status) variables were principals and teachers while the perceived level of teacher empowerment was the dependent (outcome) variable.

Instrument Reliability

Cronbach's alpha investigated the reliability of the instruments. Reliability coefficients on the School Participant Empowerment (SPES) subscales ranged from .640 for autonomy to .796 for decision making, with an overall reliability of .924, which is similar to the value of .94 reported in the literature (Short & Rinehart, 1992). The Organizational Commitment Questionnaire (OCQ) had the lowest reliability ($\alpha = .283$) among the instruments used in this study. The Professional Commitment/Job or Involvement Questionnaire (JIQ) had a slightly lower reliability ($\alpha = .649$) than what has been reported in the literature (.74 to .90) (Blau, 1985; Elloy et al., 1991; Kanungo, 1982). Bolin's (1989) Teacher Empowerment Scale ($\alpha = .895$) and the Michigan Organizational Assessment Questionnaire-Job Satisfaction Subscale (MOAQ-JSS) had acceptable reliability of $\alpha = .84$. Reliability coefficients of the instruments are presented in Table 1.

Table 1

Reliability of Instruments

| Instrument | Cronbach's Alpha | <i>N</i> of Items |
|---|------------------|-------------------|
| School Participant Empowerment Scales (SPES) | .924 | 38 |
| Decision Making Subscale | .796 | 10 |
| Profession Growth Subscale | .835 | 6 |
| Status Subscale | .748 | 6 |
| Self-efficacy Subscale | .852 | 6 |
| Autonomy Subscale | .640 | 4 |
| Impact Subscale | .734 | 6 |
| Organizational Commitment Questionnaire (OCQ) | .283 | 15 |
| Teacher Empowerment Scale | .895 | 6 |
| Professional Commitment/Job/Involvement Questionnaire (JIQ) | .649 | 10 |
| Michigan Organizational Assessment Questionnaire Job Satisfaction Subscale (MOAQ-JSS) | .840 | 3 |

Data Analysis

The author chose statistical procedures that were consistent with the research questions, hypotheses, and type of data collected, as outlined in chapters one and three. To answer the research questions and hypotheses, a series of analytical procedures for parametric statistics using SPSS and Amos 17.0 statistical software were utilized.

Research question one investigated the perceptions of K-12 Christian school teachers regarding their empowerment. To assess teachers' perceptions of empowerment among teachers in selected Christian schools, the descriptive statistics of mean, standard deviation, and range were used. This was a descriptive question, but as delineated in hypothesis one, it required inferential statistical analysis to determine whether those levels were significant. To answer this, the author computed a global score on the SPES and used that score as a test value and then used one-sample t-tests to compare the subscales to the test value. The global score is the mean score of School Participant Empowerment Scale's six subscales or dimensions: decision making, autonomy, status, professional growth, and impact. There were six one-sample t-tests since there were six variables under investigation.

Research question two investigated the effects of teacher empowerment on teachers' job satisfaction and commitment to both their schools and the teaching profession. To determine the correlations between teacher empowerment and teachers' organizational and professional commitment, and job satisfaction variables, multiple regression statistics were used to assess correlations between and among variables. Cronbach's alphas were used to test the reliability of the scales. The author wanted a regression analysis, and this was clarified in the proposal. This would ordinarily require three separate regression equations because there were three dependent variables. The author used the global SPES score indicated above as the independent variable and created a regression model using path analysis to show the influence of teacher empowerment on the dependent variables.

Research question three investigated whether the teacher's gender, level of education, years of educational experience, school type, and school size affect his/her perceptions regarding teacher empowerment. The author used the multiple regression in SPSS.

Research question four examined what dimensions of teacher empowerment (autonomy, decision making, impact, professional growth, self-efficacy, and status) can best predict teachers' commitment to their schools and their profession, and their job satisfaction. This required three separate regression equations, and the author used multiple regression in SPSS and entered the variables using the stepwise entry method. After determining which variables were significant predictors, the author used them to model the structural equation in AMOS 17.0.

Research question five investigated whether there was a significant difference between teachers' and principals' perceptions of teacher empowerment. The Bolin's Teacher Empowerment Scale instrument was used to assess the perceptions of teacher empowerment of school leaders and teachers and then utilized an independent sample t-test to statistically examine the research question.

Procedure

Approval process

Liberty University (LU) required an approval for the research by the LU Institutional Review Board (IRB). The researcher submitted the study proposal to Liberty University's Institutional Review Board, which approved the research. Since the study utilized a causal comparative research method with no foreseeable harm to participants, no other approvals were required. This researcher also sought permission to use the above

instruments for empirical research from the holders of copyrights. Permission to use the SPES (Appendix A) was granted by Dr. Paula Short in an email response to request (Appendix F). Dr. Short and her associate designed the instrument. The permission to use the Organizational Commitment Questionnaire (OCQ) (Appendix B) was sought from Dr. Mowday of the University of Oregon. Dr. Mowday notified this researcher that OCQ was initially developed by Dr. Porter, who placed it in public domain for public use and for the furtherance of scholarship. Dr. Mowday's email is shown in Appendix G. No copyrights were noted for Bolin's Teacher Empowerment Scale, Job Involvement questionnaire (JIQ), and Michigan Organizational Assessment Questionnaire Job Satisfaction Subscale (MOAQ-JSS), and they were in the public domain.

Data Collection Process

The research instruments indicated above were merged into one survey consisting of 78 questions. The questionnaires were made available to all participants electronically using SurveyGizmo, an online survey research company. Participants were not coerced in any way, as all participants received their own set of surveys or questionnaires to complete freely on their own. Privacy and confidentiality for participants were maintained as participants' identities were not required. Numbers were used rather than individual names of schools or participants. Research materials and documents and all data were confidentially secured and then destroyed after the study's report was completed.

A list of schools affiliated with ACSI was obtained from ACSI, and a random sampling was used to select the 200 schools from the two regions. There were 688 schools for the cluster sampling. Each school was allocated a number. In order to obtain

the random sample, the researcher selected every odd number, starting from the count of 100, until all the schools were factored in. The convenience sampling method has been successfully used by other researchers, such as Patton (2008) in his dissertation research titled *The Effect of School Size on the Utilization of Educational Technologies*, and Braggs (2008) in his dissertation entitled *The Application of Transformational Leadership among Christian School Leaders in the Southeast and Mid-Atlantic North Regions*. A similar sampling method was used by Koehler (1992) in his dissertation research at Kent State University titled *Personality Traits Associated with Transformational Leadership of Secondary School Principals of Christian Schools*.

The author then sent out an email with survey links to the heads of the 200 K-12 Christian schools and requested that they participate (Appendix K). They were also asked to make the survey available to their teaching staff. The author was careful to ensure that the sample represented the population relevant to the study. A total of 200 out of 688 K-12 Christian schools in the south central and northwestern regions of the United States were randomly selected to participate in the study. The selected schools were also members of the Association of Christian Schools international (ACSI). A total of 57 schools (representing 28.5%) accepted the invitation to participate. These schools had a population of 653 teachers, and 210 of these responded to the invitation to participate. Of these, 121 completed the surveys, and 89 started but did not complete the surveys. Therefore, 121 teachers (N=121) and 49 principals (N=49) were incorporated in the study. The response rate was about 29%, a rate that is not uncommon in social science studies (Bogler, 1994; Kidder, 2002). To obtain the above response rate, the author sent two additional reminder emails to the participants. The second email was sent after 3

weeks from the date of the first email, and the third was sent 2 weeks after the second email.

Data Preparation

As indicated above, the research instruments were combined into an online survey, and SurveyGizmo, an online (web based) research company, was used for the electronic collection of responses from the participants. After receiving the survey responses, the first task for the author was to code the data into a format that is compatible with Microsoft Excel or SPSS. The gender entries, for instance, were coded one for males and two for females. The coded data in MS Excel format was then imported into SPSS. Data from survey respondents who started but did not finish the survey was not included. The researcher was not concerned about outliers because the scores were computed by averaging the values of the Likert scales, which had a limited range of values. There was, therefore, not much variance, as can also be attested by the small standard deviation values.

CHAPTER FOUR: RESULTS

As delineated in both chapters one and three, the purpose of this study was to investigate the construct of teacher empowerment and its influence on teachers' commitment to their schools and their profession, and their job satisfaction. This study sought to investigate what dimensions of perceived teacher empowerment (autonomy, decision making, impact, self-efficacy, and professional growth) can best predict the aforementioned variables. Finally, the study sought to examine any disparity between school leaders' and teachers' perceptions of teacher empowerment. A combination of causal-comparative and correlational research methodologies examined these relationships. Research instruments used in this study were combined into one online survey that consisted of the following; (a) demographic survey, (b) the School Participant Empowerment Scales (SPES), (c) the Organizational Commitment Questionnaire (OCQ), (d) Bolin's Teacher Empowerment Scale, (e) Professional Commitment or Job Involvement Questionnaire (JIQ), and (f) the Michigan Organizational Assessment Questionnaire Job Satisfaction Subscale (MOAQ-JSS). Chapter 4 is organized by reporting data preparation, the population demographics, instrument reliability, hypothesis testing, and a summary of the results. Data were analyzed with SPSS and AMOS 17. The following provides information on data preparation.

Demographic Profile of the Population

Educational Attainment

Data were obtained on 170 participants; of which 71.2% ($N = 121$) were teachers and 28.8% ($N = 49$) were principals or heads of school in this research. Of the principals,

51% ($N = 25$) held master's degrees, whereas the numbers of principals with bachelor's (20.4%, $N = 10$) and doctoral degrees (20.4%, $N = 10$) were equally distributed. Among teachers, 8.2% ($N = 4$) had associate degrees, 65.3% ($N = 79$) had bachelor's degrees, 31.4% ($N = 38$) had master's degrees, and 2.5% ($N = 3$) had doctorate degrees. See Table 2.

Table 2

Highest Level of Education

| What is your job title? | Variable | Frequency | Percent |
|-------------------------|--------------------|-----------|---------|
| Principal | Associate's Degree | 4 | 8.2 |
| | Bachelor's Degree | 10 | 20.4 |
| | Master's Degree | 25 | 51.0 |
| | Doctorate | 10 | 20.4 |
| | Total | 49 | 100.0 |
| Teacher | Associate's Degree | 1 | .8 |
| | Bachelor's Degree | 79 | 65.3 |
| | Master's Degree | 38 | 31.4 |
| | Doctorate | 3 | 2.5 |
| | Total | 121 | 100.0 |

Years of Service in School Setting

The majority of principals (79.6%, $N = 39$) and teachers (70.2%, $N = 85$) had more than 7 years of service in school settings. Of principals, 2% ($N = 1$) had less than one year of service in a school setting compared to 4.1% ($N = 5$) of teachers. See Table 3.

Table 3

Participants' Years of Service in School Setting

| What is your job title? | Variable | Frequency | Percent |
|-------------------------|-------------------|-----------|---------|
| Principal | Less than 1 year | 1 | 2.0 |
| | 1 to 2 years | 3 | 6.1 |
| | 3 to 5 years | 6 | 12.2 |
| | More than 7 years | 39 | 79.6 |
| | Total | 49 | 100.0 |
| Teacher | Less than 1 year | 5 | 4.1 |
| | 1 to 2 years | 13 | 10.7 |
| | 3 to 5 years | 18 | 14.9 |
| | More than 7 years | 85 | 70.2 |
| | Total | 121 | 100.0 |

Gender

Most of the principals were males (53.1%, $N = 26$), and 46.9% ($N = 23$) were females. However, the majority of teachers were females (82.6%, $N = 100$), and 17.4% ($N = 21$) of teachers were males.

Size of School

Principals and teachers had similar responses when asked about the sizes of their schools based on total student enrollment for all grade levels. For instance, approximately one-third (28.6%, $N = 14$) of principals were at schools with 501 to 1,000 students, and one-third (32.7%, $N = 16$) were at schools with 101 to 300 students. Similarly, one-third of teachers (33.9%, $N = 41$) were at schools with 501 to 1,000

students, and one-third of teachers (32.2%, $N = 39$) were at schools with 101 to 300 students. See Table 4.

Table 4

Size of School Based on Total Student Enrollment

| What is your job title? | Variable | Frequency | Percent |
|-------------------------|----------------|-----------|---------|
| Principal | Less than 100 | 12 | 24.5 |
| | 101 to 300 | 16 | 32.7 |
| | 301 to 500 | 6 | 12.2 |
| | 501 to 1000 | 14 | 28.6 |
| | More than 1000 | 1 | 2.0 |
| | Total | 49 | 100.0 |
| Teacher | Less than 100 | 16 | 13.2 |
| | 101 to 300 | 39 | 32.2 |
| | 301 to 500 | 25 | 20.7 |
| | 501 to 1000 | 41 | 33.9 |
| | Total | 121 | 100.0 |

Research Questions and Hypothesis Testing

Five research questions and five related hypotheses were formulated for investigation. The following provides a discussion of the results.

Research Question 1

What are the perceptions of K-12 Christian school teachers regarding their empowerment?

The mean scores on the six subscales or dimensions of School Participant Empowerment Scale (SPES) ranged from 2.68 to 4.76 ($M = 3.87$, $SD = 0.45$). Teachers scored the highest on the self-efficacy subscale of the SPES ($M = 4.49$, $SD = 0.44$) and scored the lowest on the decision making subscale ($M = 2.98$, $SD = 0.63$). Descriptive

statistics of the School Participant Empowerment Scale (SPES) are provided in Table 5. The global score or the mean score of all subscales of SPES was 3.87.

Table 5

Descriptive Statistics for the School Participant Empowerment Scale

| Variable | <i>N</i> | <i>Min.</i> | <i>Max.</i> | <i>M</i> | <i>SD</i> |
|---------------------|----------|-------------|-------------|----------|-----------|
| Decision Making | 121 | 1.10 | 4.38 | 2.98 | 0.63 |
| Professional Growth | 121 | 1.33 | 5.00 | 4.04 | 0.68 |
| Status | 121 | 2.83 | 5.00 | 4.32 | 0.43 |
| Self-efficacy | 121 | 3.50 | 5.00 | 4.49 | 0.44 |
| Autonomy | 121 | 1.25 | 5.00 | 3.65 | 0.73 |
| Impact | 121 | 2.83 | 5.00 | 4.25 | 0.45 |
| SPES (Total) | 121 | 2.68 | 4.76 | 3.87 | 0.45 |

Hypothesis 1

- H₀1₁ There is no significant level of perceived teacher empowerment related to decision-making as measured by School Participant Empowerment Scale (SPES).
- H₀1₂ There is no significant level of perceived teacher empowerment related to autonomy as measured by School Participant Empowerment Scale (SPES).
- H₀1₃ There is no significant level of perceived teacher empowerment related to professional growth as measured by School Participant Empowerment Scale (SPES).
- H₀1₄ There is no significant level of perceived teacher empowerment related to impact as measured by School Participant Empowerment Scale (SPES).

H₀₁₅ There is no significant level of perceived teacher empowerment related to status as measured by School Participant Empowerment Scale (SPES).

H₀₁₆ There is no significant level of perceived teacher empowerment related to self-efficacy as measured by School Participant Empowerment Scale (SPES).

Six one-sample t-tests investigated H₀₁. The t-test was implemented to determine whether the six subscales deviated significantly from the global score or mean score of 3.87 (test value) on the SPES. The global score is the mean score of School Participant Empowerment Scale's six subscales or dimensions: decision making, autonomy, status, professional growth, and impact.

All of the subscale scores were significantly different than the global score. Specifically, decision making was significantly lower than the global or mean score of 3.87; $t(120) = -15.37, p < .001$, two-tails. Likewise, autonomy was significantly lower than the global score of 3.87; $t(120) = -3.39, p < .001$, two-tails. However, professional growth, impact, status, and self-efficacy were significantly higher than the global score. Christian school teachers scored the highest in self efficacy, $t(120) = 15.45, p < .001$, two-tails; followed by status, $t(120) = 11.43, p < .001$, two-tails; impact, $t(120) = 9.15, p < .001$, two-tails; and professional growth, $t(120) = 2.70, p = .008$, two-tails. Therefore, H₀₁ including sub-hypotheses H₀₁₁, H₀₁₂, H₀₁₃, H₀₁₄, H₀₁₅, and H₀₁₆, was rejected.

Figure 1 is a chart showing the SPES global score.

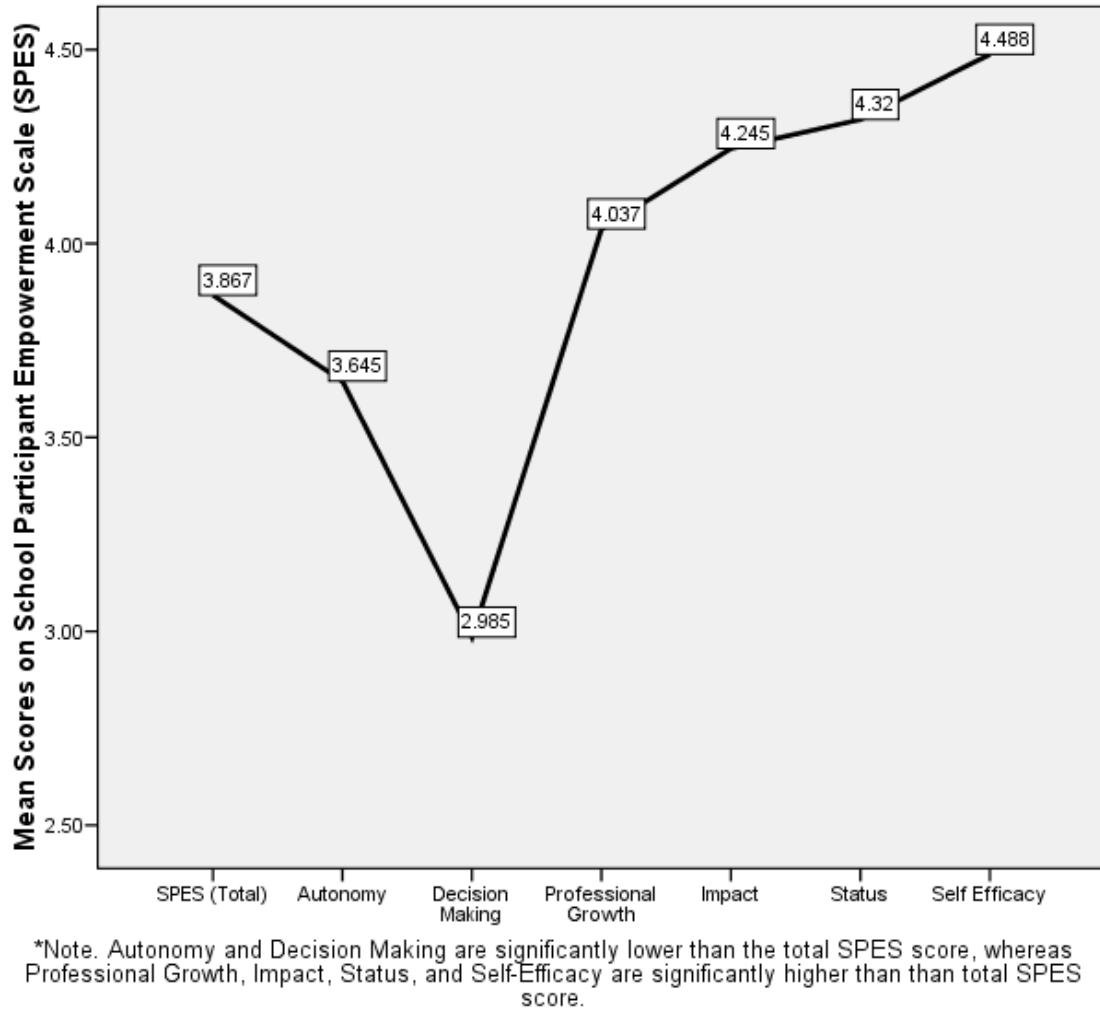

Figure 1. Significant Levels of Perceived Empowerment

Research Question 2

What are the effects of teacher empowerment on teachers' job satisfaction and commitment to both their schools and the teaching profession?

Multiple regression investigated research question two. Teacher's perceived empowerment was the independent variable as assessed by the School Participant Empowerment Scale (SPES). There were three dependent variables; a) teacher job satisfaction as measured by the Michigan Organizational Assessment Questionnaire Job Satisfaction Subscale (MOAQ-JSS), b) teacher commitment to the schools as measured

by the Organizational Commitment Questionnaire (OCQ), and c) teacher commitment to the teaching profession as measured by the Job Involvement Questionnaire (JIQ). AMOS 17.0 was better suited to address this research question than SPSS because this question would require three separate regression equations (one for each dependent variable) with SPSS, whereas in AMOS 17.0, all three regression equations can be computed and illustrated simultaneously. Teacher empowerment was a significant, positive predictor of job satisfaction ($\beta = 0.35$, $R^2 = .12$; $p < .001$). As teachers felt more empowered, there was a corresponding increase in their job satisfaction. Teacher empowerment was a significant, positive predictor of teacher commitment to their schools ($\beta = 0.48$, $R^2 = .23$, $p < .001$). As teachers felt more empowered, there was a corresponding increase in their commitment to their schools. Teacher empowerment was a significant, positive predictor of commitment to the teaching profession ($\beta = 0.38$, $R^2 = .14$; $p < .001$). As teachers felt more empowered, there was a corresponding increase in their commitment to the teaching profession.

Figure 2 shows a path diagram of these relationships. The figure shows that teacher empowerment influences or predicts three dependent or outcome variables of organizational commitment, professional commitment, and job satisfaction as measured by Organizational Commitment Questionnaire (OCQ), Job Involvement Questionnaire (JIQ), and Michigan Organizational Assessment Questionnaire Job Satisfaction Subscale (MOAQ-JSS). The standardized regression weights are included. For instance, the standardized regression weight for teacher empowerment predicting teacher commitment to their schools is .48. The R-squared value for this prediction is .23, which is also indicated in the diagram. This means that 23% of the variance in teacher commitment to

their schools can be explained by teacher empowerment. Similarly, 14% of the variance in commitment to the teaching profession can be accounted for by teacher empowerment, and 12% of the variance in teacher job satisfaction can be accounted for by teacher empowerment. The figure also displays the error terms in the predictions. Error terms represent measurement error or the amount of variance in the prediction that is unexplained. In this figure, the error term for OCQ is correlated with the error term for MOAQ-JSS ($r = .27$). A p-value of .278 means that there is no significant difference between the path model and the data. Thus, the model is an acceptable representation of the relationships between the variables of interest.

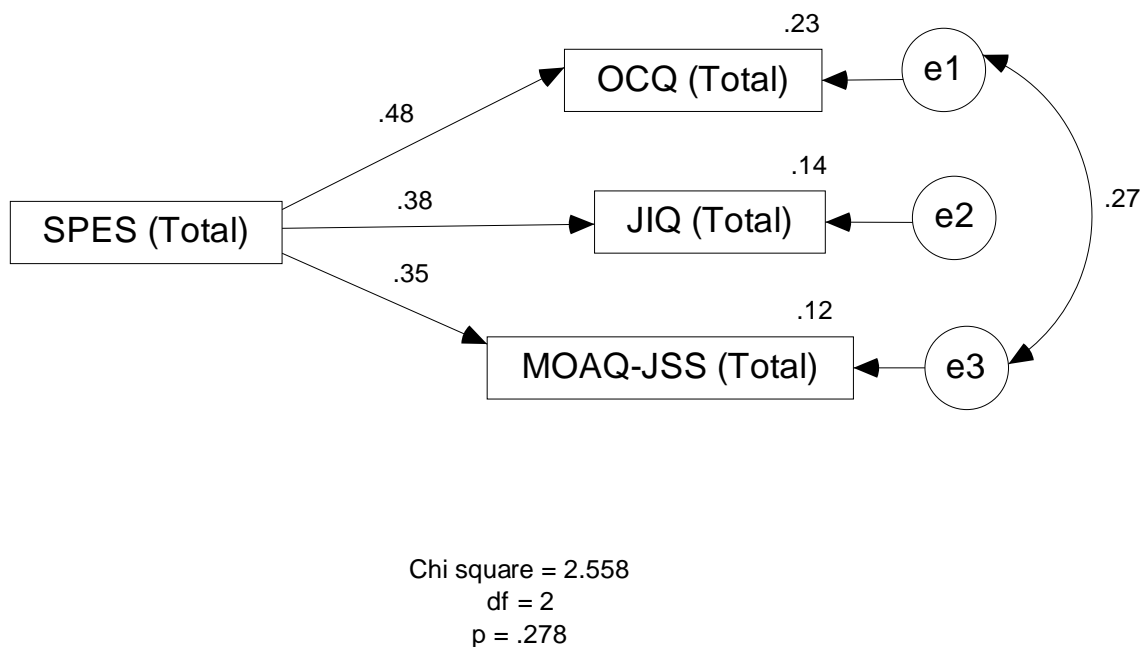

Figure 2. Effects of Teacher Empowerment

Hypothesis 2

The perception of empowerment of K-12 Christian school teachers has no significant correlation with their commitment to their schools and their profession, and their job satisfaction as measured by Michigan

Organizational Assessment Questionnaire-Job Satisfaction Subscale (MOAQ-JSS), Organizational Commitment Questionnaire (OCQ), and the Job Involvement Questionnaire (JIQ).

H₀₂₁ The perception of empowerment of K-12 Christian school teachers has no significant correlation with commitment to their schools.

H₀₂₂ The perception of empowerment of K-12 Christian school teachers has no significant correlation with commitment to their profession.

H₀₂₃ The perception of empowerment of K-12 Christian school teachers has no significant correlation with their job satisfaction.

A correlation matrix for the variables of interest is presented in Table 6.

Table 6

Zero-Order Correlations

| Measure | 1 | 2 | 3 | 4 | <i>M</i> | <i>SD</i> |
|-------------|-------|-------|-------|-------|----------|-----------|
| 1. SPES | – | .48** | .38** | .35** | 3.87 | .45 |
| 2. OCQ | .48** | – | .26** | .39** | 4.86 | .47 |
| 3. JIQ | .38** | .26** | – | .06 | 3.00 | .52 |
| 4. MOAQ-JSS | .35** | .39** | .06 | – | 3.51 | .41 |

Note. ** Correlation is significant at the 0.01 level (2-tailed). 1. SPES = School Participant Empowerment Scales, 2. OCQ = Organizational Commitment Questionnaire, 3. JIQ = Professional Commitment/Job Involvement Questionnaire, 4. MOAQ-JSS = Michigan Organizational Assessment Questionnaire Job Satisfaction Subscale, *N* = 121.

Teacher empowerment was significantly related to organizational commitment, $r = .48$, $N = 121$, $p < .001$, two-tails professional commitment, $r = .38$, $N = 121$, $p < .001$, two-tails and job satisfaction, $r = .34$, $N = 121$, $p < .001$, two-tails. Therefore, H₀₂, including sub-hypotheses H₀₂₁, H₀₂₂, and H₀₂₃, was rejected.

Research Question 3

Does a teacher's gender, level of education, years of educational experience, school type, and school size affect his/her perceptions regarding teacher empowerment?

Multiple regression determined that collectively these variables did not significantly influence teacher empowerment. The ANOVA for the model was not statistically significant $F(5, 115) = 1.29, p = .27$. However, gender was significantly associated with teacher empowerment ($\beta = .21, p = .04$).

Hypothesis 3

The K-12 school teacher's gender, level of education, school type, and school size have no significant effect on perception of their empowerment as measured by School Participant Empowerment Scale (SPES).

H₀₃₁ Gender does not have a significant effect on a teacher's perception of their empowerment.

H₀₃₂ Level of education does not have a significant effect on a teacher's perception of their empowerment.

H₀₃₃ School type does not have a significant effect on a teacher's perception of their empowerment.

H₀₃₄ Size of school does not have a significant effect on a teacher's perception of their empowerment.

As indicated above, level of education, school type, and school size did not have any significant influence on a teacher's perception of teacher empowerment. However, gender was significantly associated with teacher empowerment. Male teachers felt significantly more empowered than female teachers. Therefore, sub hypothesis H₀₃₁ was

rejected while sub hypotheses H₀₃₂, H₀₃₃, and H₀₃₄ were accepted. Regression coefficients are presented in Table 7.

Table 7

Regression Coefficients for Teacher Empowerment and Demographic Variables

| Model | | Unstandardized Coefficients | | Standardized Coefficients | <i>t</i> | <i>p</i> |
|-------|---|-----------------------------|-------------------|---------------------------|----------|------------|
| | | <i>B</i> | <i>Std. Error</i> | <i>Beta</i> | B | Std. Error |
| 1 | (Constant) | 4.14 | 1.02 | | 4.06 | .000 |
| | Participant's highest level of education? | .01 | .08 | .01 | .12 | .903 |
| | Participant's years of service in school setting. | .05 | .03 | .13 | 1.39 | .166 |
| | Participant's gender. | .25 | .12 | .21 | 2.08 | .040 |
| | What school grade level do you teach? | -.06 | .05 | -.12 | -1.15 | .255 |
| | What is the size of your school based on total student enrollment for all grade levels? | -.01 | .04 | -.01 | -.13 | .895 |

Note. Dependent Variable = SPES (Total)

Research Question 4

What dimensions of teacher empowerment (autonomy, decision making, impact, professional growth, self-efficacy, and status) can best predict teachers' commitment to their schools and their profession, and their job satisfaction?

Hypothesis 4

The teachers' perceived empowerment dimensions of autonomy, decision making, impact, professional growth, self-efficacy, and status are not

significant predictors of their organizational commitment, professional commitment, and job satisfaction as measured by School Participant Empowerment Scale, Organizational Commitment Questionnaire (OCQ), Job Involvement Questionnaire (JIQ) (Professional Commitment), and Michigan Organizational Assessment Questionnaire Job Satisfaction Subscale (MOAQ-JSS).

H₀4₁ The teachers' perceived empowerment dimension of autonomy is not a significant predictor of their organizational commitment.

H₀4₂ The teachers' perceived empowerment dimension of autonomy is not a significant predictor of their professional commitment.

H₀4₃ The teachers' perceived empowerment dimension of autonomy is not a significant predictor of their job satisfaction.

H₀4₄ The teachers' perceived empowerment dimension of decision making is not a significant predictor of their organizational commitment.

H₀4₅ The teachers' perceived empowerment dimension of decision making is not a significant predictor of their professional commitment.

H₀4₆ The teachers' perceived empowerment dimension of decision making is not a significant predictor of their job satisfaction.

H₀4₇ The teachers' perceived empowerment dimension of impact is not a significant predictor of their organizational commitment.

- H₀₄₈ The teachers' perceived empowerment dimension of impact is not a significant predictor of their professional commitment.
- H₀₄₉ The teachers' perceived empowerment dimension of impact is not a significant predictor of their job satisfaction.
- H₀₄₁₀ The teachers' perceived empowerment dimension of professional growth is not a significant predictor of their organizational commitment.
- H₀₄₁₁ The teachers' perceived empowerment dimension of professional growth is not a significant predictor of their professional commitment.
- H₀₄₁₂ The teachers' perceived empowerment dimension of professional growth is not a significant predictor of their job satisfaction.
- H₀₄₁₃ The teachers' perceived empowerment dimension of self-efficacy is not a significant predictor of their organizational commitment.
- H₀₄₁₄ The teachers' perceived empowerment dimension of self-efficacy is not a significant predictor of their professional commitment.
- H₀₄₁₅ The teachers' perceived empowerment dimension of self-efficacy is not a significant predictor of their job satisfaction.
- H₀₄₁₆ The teachers' perceived empowerment dimension of status is not a significant predictor of their organizational commitment.
- H₀₄₁₇ The teachers' perceived empowerment dimension of status is not a significant predictor of their professional commitment.

H₀₄₁₈ The teachers' perceived empowerment dimension of status is not a significant predictor of their job satisfaction.

Multiple regression using the stepwise variable entry method determined that professional growth and decision making best predicted teachers' commitment to their schools and their profession, and their job satisfaction. After the predictor variables were identified with SPSS, AMOS 17.0 was used to create a structural equation model. Specifically, professional growth ($\beta = .32, p = .003$) and decision making ($\beta = .24, p = .024$) were significant predictors of teachers' commitment to their schools, $R^2 = .26$. Decision making was a significant predictor of teachers' commitment to their profession, $\beta = .24, p < .001, R^2 = .14$. Professional growth was a significant predictor of teacher job satisfaction, $\beta = .45, p < .001, R^2 = .20$. The measurement error for teachers' commitment to their schools was significantly related to the measurement error for teacher job satisfaction, $r = .23, N = 121, p = .014$. Professional growth was significantly related to decision making, $r = .69, N = 121, p < .001$. A p-value of .57 means that there is no significant difference between the path diagram and the data. Therefore, the model is an acceptable representation of the data. See Figure 3.

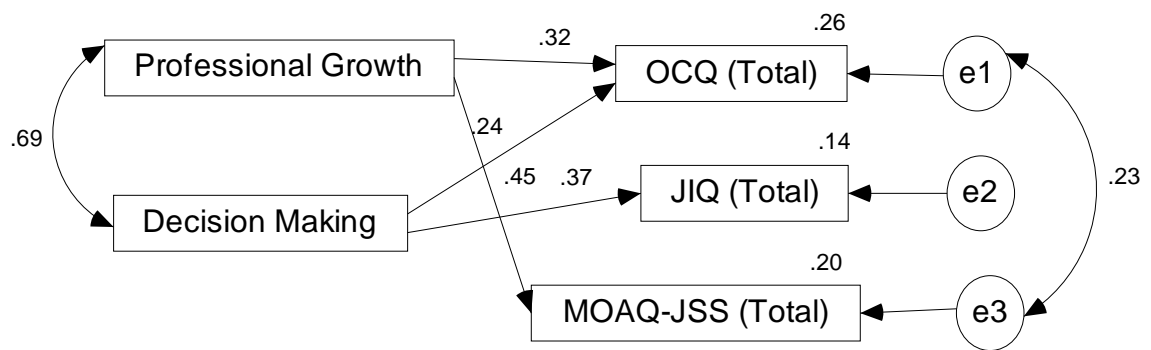

Chi square = 2.959
df = 4
p = .565

Figure 3. Dimensions of teacher empowerment

Hypothesis four stated that the teacher's perceived empowerment dimensions of autonomy, decision making, impact, professional growth, self-efficacy, and status are not significant predictors of teachers' organizational commitment, professional commitment, and job satisfaction. This hypothesis was rejected. However, professional growth and decision making were significant predictors of teachers' organizational commitment, professional commitment, and job satisfaction. The empowerment dimensions of autonomy, impact, self-efficacy, and status were not significant predictors, as they were statistically removed from the models. Therefore, sub hypotheses H_{o41}, H_{o42}, H_{o43}, H_{o47}, H_{o48}, H_{o49}, H_{o413}, H_{o414}, H_{o415}, H_{o416}, H_{o417}, and H_{o418} were accepted while sub hypotheses H_{o44}, H_{o45}, H_{o46}, H_{o410}, H_{o411}, and H_{o412} were rejected.

Research Question 5

Is there a significant difference between teachers' and principals' perceptions of teacher empowerment?

Hypothesis 5

There will be no significant difference in how principals and teachers perceive empowerment as measured by Bolin's Teacher Empowerment Scale.

An independent sample t-test examined research question five. Teachers' perceptions of teacher empowerment ($M = 2.93$, $SD = 0.99$) were significantly lower than principals' perceptions of teacher empowerment ($M = 4.48$, $SD = 1.01$); $t(168) = 9.17$, $p < .001$, two-tails.

Principals ($M = 2.93$, $SD = 0.99$) perceived teacher empowerment significantly higher than teachers ($M = 4.48$, $SD = 1.01$) perceived teacher empowerment; $t(168) = 9.17$, $p < .001$, two-tails. Therefore, H_{05} was rejected.

Summary of Results

Table 8 provides a summary of the results.

Table 8

Summary of Results

| Hypothesis | Null Accepted or Rejected |
|--|--|
| <p>Hypothesis 1: There will be no significant level of empowerment as perceived by K-12 Christian schools teachers in regard to the six dimensions of School Participant Empowerment Scale (SPES) as measured by SPES.</p> | <p>Decision making and autonomy were significantly lower than the global score (the mean score of six dimensions of SPES), whereas professional growth, impact, status, and self efficacy were significantly higher than the global score. Therefore, H_{01_1}, H_{01_2}, H_{03_3}, H_{01_4}, H_{01_5}, and H_{01_6} were rejected.</p> |
| <p>Hypothesis 2: The perceived empowerment of K-12 Christian school teachers has no significant correlation with commitment to their schools and their profession, and their job satisfaction.</p> | <p>Perceived teacher empowerment was significantly related to organizational commitment, professional commitment, and job satisfaction. Therefore, H_{02} and sub-hypotheses H_{02_1}, H_{02_2}, and H_{02_3} were rejected.</p> |
| <p>Hypothesis 3: The K-12 school teacher's gender, level of education, school type, and school size have no significant effect on teacher's perception of their empowerment.</p> | <p>Level of education, school type, and school size did not have any significant influence on teacher's perception of teacher empowerment. However, gender was significantly associated with teacher empowerment. Male teachers felt significantly more empowered than female teachers. Therefore, H_{03} and sub hypothesis H_{03_1} were rejected, but sub hypotheses H_{03_2}, H_{03_3}, and H_{03_4} were accepted.</p> |

Hypothesis 4:

The perceived teacher empowerment dimensions of autonomy, decision making, impact, professional growth, self-efficacy, and status are not significant predictors of teacher's organizational commitment, professional commitment, and job satisfaction.

Professional growth and decision making were significant predictors of teachers' organizational commitment, professional commitment, and job satisfaction. The empowerment dimensions of autonomy, impact, self-efficacy, and status were not significant predictors, as they were statistically removed from the models. Therefore, hypothesis H_{o4} and sub hypotheses H_{o44}, H_{o45}, H_{o46}, H_{o410}, H_{o411}, and H_{o412} were rejected while. H_{o41}, H_{o42}, H_{o43}, H_{o47}, H_{o48}, H_{o49}, H_{o413}, H_{o414}, H_{o415}, H_{o416}, H_{o417}, and H_{o418} were accepted.

Hypothesis 5:

There will be no significant difference in how principals and teachers perceive empowerment as measured by Bolin's Teacher Empowerment Scale.

Principals perceived teacher empowerment significantly higher than teachers perceived teacher empowerment. Therefore, H_{o5} was rejected.

CHAPTER FIVE: DISCUSSION OF FINDINGS AND IMPLICATIONS

This chapter provides a discussion of research findings and their implications in light of the relevant literature. In addition, the author provides an outline of other incidental findings, limitations of the study, a succinct summary of primary findings that will conclude the manuscript, and recommendations for future research.

Discussion of the Research Findings

Hypothesis 1

The six sub hypotheses examined whether there was significant level of empowerment as perceived by K-12 Christian schools teachers as relates to the six dimensions of School Participant Empowerment Scale (SPES): decision making, autonomy, professional growth, impact, status, and self-efficacy. As noted above this hypothesis had six sub-hypotheses that focused on the six dimensions of teacher empowerment as measured by SPES. The six dimensions of SPES were found to significantly deviate from the global score of SPES. The global score is the mean score of School Participant Empowerment Scale's six subscales or dimensions: decision making, autonomy, status, professional growth, and impact.

Decision making and autonomy were significantly lower than the global score, whereas professional growth, impact, status, and self efficacy were significantly higher than the global score. These findings suggest that the K-12 Christian school teachers in this study had significant perception levels of teacher empowerment. The highest levels of teacher empowerment were reflected in the SPES subscales of self-efficacy, status, and

impact in that order. Decision making and autonomy had lower scores than the global score of SPES. The findings regarding the means of SPES subscales of teacher empowerment appeared to concur with other previous studies. In their study, Wall and Rinehart (1998) found that the dimensions of teacher empowerment (SPES) were significant in the following descending order: self efficacy, impact, professional growth, autonomy, and decision making. Similar findings appeared in a study conducted by Bogler and Somech (2004). In an exploratory study involving career and technical educational teachers in one Midwestern state, Scribner et al. (2001) found that the level of empowerment for career and technical education teachers varied across the six subscales. The lowest subscale mean was decision making, followed by autonomy and professional growth. The highest subscale means were found to be self-efficacy, status, and impact, in that order. These findings largely mirrored the findings of the present study.

The study outcomes suggest that teachers in selected K-12 Christian schools had a high sense of self-efficacy and impact. Self-efficacy is the perception that one has the capacity to perform, and this translates to a sense of competence. In another study, Gibson and Dembo (1984) found that teachers perform better when they believe that they can make a difference with their students. The importance of self-efficacy can be best understood by looking at the original concept as developed by Bandura (1977). Bandura posited that self-efficacy is based on two dimensions: efficacy expectancy and outcome expectancy. The former implies that the individual believes that a given behavior will result in certain outcomes, and the latter refers to behaviors toward the expected outcomes. It is evident that teachers with higher degrees of self-efficacy demonstrate

more organizational behaviors. Teachers who exhibit high expectations of themselves to perform effectively and successfully in school will carry out functions beyond the formal ones and will feel more committed to their school and to the teaching profession (Bogler & Somech, 2004).

The other School Participant Empowerment Scale (SPES) subscales where the K-12 Christian teachers exhibited high perception levels of empowerment are status and impact. Status refers to the teacher's sense of esteem and the professional respect given to the teacher by students, parents, supervisors, and the community (Ashton & Webb, 1986). Teacher impact is defined as the teachers' perceptions that they have influence over their work life (Short & Rinehart, 1992a). The findings paralleled the results from other studies such as Scribner et al. (2001) and Bogler and Somech (2004). Teachers who have a high sense of status in their work tend to invest more and feel more committed to their organization (Bogler & Somech, 2004).

According to the findings of this present study, decision making had the lowest ranking, followed by autonomy and professional growth. This means that K-12 Christian school teachers did not feel that they were given the liberty or empowered enough to make decisions, have control over various aspects of their work life (autonomy), or have opportunities for professional growth. These findings are congruent with findings depicted in studies by Bogler and Somech (2004) and Scribner et al. (2001), in which teachers registered low empowerment perception levels on subscales of decision making and autonomy.

The current findings are important because educational reform efforts require teacher involvement in many aspects of school affairs. When teacher perceptions of their

involvement in critical school decisions are low, school reform efforts are negatively impacted (Scribner et al., 2001). The implication for Christian school leaders is that they need to foster a participative leadership environment where teachers are afforded more latitude in decision-making processes as they relate to salient issues of school life: curriculum, budgets, hiring of new teachers, scheduling, and goal setting or strategic planning. Christian school leaders should embrace the tenets of transformational leadership by forging a collaborative leadership alliance with their teachers. This translates to the practical incorporation of teachers in the governance of their schools.

Hypothesis 2

Hypothesis two stated that the perceived empowerment of K-12 Christian school teachers had no significant correlation with their commitment to their schools and their profession, and their job satisfaction.

Three sub-hypotheses were generated to test the primary hypothesis. H_{02_1} focused on teachers' commitment to their school, H_{02_2} focused on teachers' commitment to their profession, and H_{02_3} dealt with teachers' job satisfaction. The null hypothesis and subsequent sub-hypotheses H_{02_1} , H_{02_2} , and H_{02_3} were rejected as the K-12 Christian school teachers in this study indicated that teacher empowerment was significantly related to organizational commitment, professional commitment, and job satisfaction. As delineated in chapter four, teacher empowerment was a significant, positive predictor of teacher commitment to their schools. As teachers felt more empowered, there was a corresponding increase in their commitment to their schools. Teacher empowerment was a significant, positive predictor of commitment to the teaching profession. The study

found that as teachers felt more empowered, there was a corresponding increase in their organizational commitment, professional commitment, and job satisfaction.

This conclusion was similar to the ones derived from other studies including Bogler and Somech (2004), Scribner et al. (2001), Wu and Short (1996), and Cohen (2000). For example, Bogler and Somech (2004) conducted a study in Israel that involved 983 middle and high school teachers, and the findings indicated that teachers' perceptions of their level of empowerment correlated significantly to their feelings of commitment to their organization and profession. Like the findings of this present study, Rinehart and Short (1994) found that teacher empowerment was positively correlated with job satisfaction. The same conclusion was also drawn from a study conducted by Wu and Short (1996). In addition, a plethora of research studies has revealed that leadership behavior has a direct bearing on employees' job satisfaction (Griffin & Bateman, 1978). A study conducted by Maeroff (1998) also found job satisfaction to be positively associated with transformational leadership. Transformational leadership, in essence, embraces the construct of empowerment. When teachers are satisfied with their work and school life in general, they are likely to be more effective in their teaching, and this may potentially result in better school outcomes.

This study revealed that organizational commitment was mediated by teacher empowerment. The teachers' perception levels of empowerment correlated positively with a sense of commitment to their schools. The concept of organizational commitment is based on the acceptance of the organization's goals and values (identification), the willingness to invest effort on behalf of the organization (involvement), and the importance attached to keeping the membership in the organization (loyalty) (Bogler &

Somech, 2004). The construct of organizational commitment has also been positively related to better teacher performance and retention (Bogler & Somech, 2004; Egley et al., 2005). It is therefore apparent that the teachers who register high degrees of commitment to their schools have low turnover rates. This fact supports the clarion need for leaders in Christian schools to promote school ideals and culture that boost teachers' commitment to and identification with their institutions.

Hypothesis 3

Hypothesis three stated that gender, level of education, school type, and school size have no significant effect on the teacher's perception of their empowerment. Four sub-hypotheses were generated to test the aforementioned variables. H₀₃₁ focused on gender, H₀₃₂ on level of education, H₀₃₃ on school type, and H₀₃₄ on the size of school.

Results in this study found that the level of education, school type, and school size did not have any significant influence on the teacher's perception of their empowerment. The primary hypothesis (H₀₃) and sub-hypotheses H₀₃₂, H₀₃₃, and H₀₃₄, were rejected. However, gender was significantly associated with teacher empowerment. Male teachers felt significantly more empowered than female teachers. Therefore, H₀₃₁ was accepted. This finding on gender as a significant predictor of teachers' perception of empowerment mirrors the findings by Scribner et al. (2001), which found statistically significant interaction between gender and SPES subscales. The Scribner et al. (2001) study, which was conducted in public school settings, suggests that while both men and women experience empowerment similarly, gender appears to impact how teachers experience different dimensions of empowerment.

In the present study female teachers conspicuously registered low levels of empowerment in decision-making and autonomy subscales. This may mean that K-12 Christian school leaders should give female teachers a bigger role in the decision-making process. This is important when considering the fact that female teachers constitute a big majority of the teaching workforce in Christian schools, as observed in the present study.

The above finding regarding a teacher's level of education having no effect on the teacher's sense of empowerment is in contrast with the study by Scribner et al. (2001), which found a teacher's level of education relates in a significant way to empowerment. This author had hypothesized that a teacher's level of education had no significant effect on the teacher's perception of empowerment. This sub-hypothesis (H_{032}) was accepted in the present study. This finding means that Christian school leaders empowered teachers equitably regardless of level of education, and this is a commendable practice. This suggests that on the basis of educational levels, teachers did not perceive empowerment differently. Like the present study, Bogler and Somech (2004) found no inter-correlations between gender and type of school and variables of teacher empowerment, organizational commitment, professional commitment, and organizational citizenship behavior.

Hypothesis 4

Hypothesis four stated that the perceived teacher empowerment dimensions of autonomy, decision making, impact, professional growth, self-efficacy, and status are not significant predictors of their organizational commitment, professional commitment, and job satisfaction. Findings from this study indicated that professional growth and decision making were significant predictors of teachers' organizational commitment, professional

commitment, and job satisfaction. The empowerment dimensions of autonomy, impact, self-efficacy, and status were not significant predictors, as they were statistically removed from the models. Therefore, the primary hypothesis (H₀₄) as well as the sub-hypotheses H₀₄₄, H₀₄₅, H₀₄₆, H₀₄₁₀, H₀₄₁₁, and H₀₄₁₂ were rejected while H₀₄₁, H₀₄₂, H₀₄₃, H₀₄₇, H₀₄₈, H₀₄₉, H₀₄₁₃, H₀₄₁₄, H₀₄₁₅, H₀₄₁₆, H₀₄₁₇, and H₀₄₁₈ were accepted. The results somewhat contrast with the findings garnered from the study by Wu and Short (1998), which found that SPES subscales were significantly correlated with teacher empowerment. The subscales were ranked in descending order as follows: status, self-efficacy, impact, professional growth, autonomy, and decision making. These results were consistent with the findings from Bogler and Somech (2004). The findings suggest that teachers feel that they are shown respect (status), are given opportunities for professional growth, are effective at their job (impact), and have competence (self-efficacy). As in both of these studies conducted in the arena of public schools, teachers in K-12 Christian schools who participated in the study did not feel that they were given opportunities to engage in the decision-making process. In the study conducted by Bogler and Somech (2004), only self-efficacy and status predicted the three outcomes of organizational commitment, professional commitment, and job satisfaction. Bogler and Somech (2004) further observed that professional growth predicted organizational and professional commitment. In the study by Wu and Short (1998), professional growth, self-efficacy, and status predicted organizational commitment and explained 45% of the variance. The same subscales were observed to explain 44% of the variance of organizational commitment in Bogler and Somech (2004).

The conclusions drawn from the findings of this study indicated above attest to the need for Christian school leaders to provide teachers with prescriptive opportunities for professional development. This can be accomplished in a number of ways that may include allocation of time or paid leave for studies, in-service training, provision of scholarships, and promotion and pay raise based on the level of education. With such incentives, teachers would be motivated to pursue higher education and career goals. When this is done, teachers would become more competent as professionals, and this could essentially translate to better school outcomes.

Hypothesis 5

Hypothesis five stated that there will be no significant difference in how principals and teachers perceive teacher empowerment. In the present study the results revealed that principals perceived teacher empowerment significantly higher than teachers perceived teacher empowerment. The hypothesis was therefore rejected. This conclusion mirrored a study conducted by Keisher and Shen (2000), which studied public school principals' and teachers' perceptions of teacher empowerment. The study divulged a clear disparity in principals' and teachers' perceptions of the extent of teacher empowerment. The findings from these studies suggest that teachers felt that they had little influence on school-wide issues such as curriculum, scheduling, budgets, strategic planning, and hiring of new staff. The resulting discrepancy between the principals' and teachers' views of teacher empowerment clearly suggests that principals regard themselves to be more transformational and empowering while teachers do not feel as empowered. In a nutshell, it is empirically sound to infer that teachers from the K-12 Christian schools who participated in this study did not perceive Christian school leaders

as fully practicing the essential features of transformational leadership as reported from lack of sense of teacher empowerment in the SPES key dimensions of decision making and autonomy.

Implications of the Study

There are many aspects of transformational leadership and teacher empowerment that are yet to be learned, especially in K-12 Christian schools. As the review of the literature has shown, transformational leadership and teacher empowerment have not received investigative attention in K-12 Christian schools. But it is encouraging to observe that transformational leadership can be learned (Bass & Riggio, 2006).

The findings of this study might contribute to a better understanding of the practice of transformational leadership and teacher empowerment. This study will potentially help stakeholders in Christian education better understand transformational leadership and empowerment and the myriad of benefits associated with these constructs. The benefits include better teacher involvement in areas such as curriculum development, school policy initiatives, budgetary measures, and strategic planning.

The data collected shall add to the limited data currently available in the arena of Christian schools and transformative leadership. Furthermore, the research will potentially inform school leaders and other stakeholders of the dynamic resources and benefits of transformational leadership and teacher empowerment, both of which can be harnessed to achieve excellent school outcomes, as studies noted in the literature review have indicated.

It is predicted that the results of this study will assist Christian school leaders in their efforts to transform their schools with the goal of achieving excellent school

outcomes and exemplary professional growth through intentional teacher empowerment. By empowering teachers, leaders can help create synergistic learning communities (Fullan, 2007). In reality, progressive schools in the 21st century should be seen as communities of learners capable of transforming themselves and shaping both the community and school culture (Fullan, 2007).

As posited above, the benefits of teacher empowerment cannot be overstated, and the implications for Christian school leaders are profound. These implications include teacher empowerment as a factor that affects pedagogical quality and student academic performance indirectly through school organization for instruction. This author holds the view that participation in school decision making can enhance teachers' commitment to the school mission, expertise, collegiality, and, ultimately, student achievement

In order for Christian school leaders, teachers, and students to reap these benefits, they need to foster a culture of authentic teacher empowerment in their schools. This calls for transformational leadership and translates into teachers being recognized and appreciated for their contribution to school success, being accorded opportunities for professional growth, and being allowed to make decisions that influence their schools and work life. It calls for school leaders to be more willing to share power with teachers as they perpetuate a culture of teacher empowerment for the overall good of both the school and the community.

Other Incidental Findings

Although it was not part of the purpose of the present study, this author observed that the ratio of female teachers to male teachers was almost 4:1. Despite a commanding representation of women, there was not a corresponding representation of women in

leadership. Although this huge representation of women in the study does not necessarily suggest similar representation in K-12 Christian schools overall, it does point to the probability that there are more women teachers than male teachers in K-12 Christian schools. Despite this reality, there are fewer women school leaders. The study showed 53% of principals were males and 47% were women. It is the view of this author that female teachers should be empowered and afforded more opportunities for more leadership roles in K-12 Christian schools as they generally constitute the majority of the teaching workforce. This can be augmented by the fact that transformational leadership is about sharing power of governance and responsibilities. The onus is on governing school boards to promote more hiring of qualified female teachers as school leaders in Christian schools.

Limitations of the Study

The object of this research was to investigate the inter-correlations between teacher empowerment and variables of job satisfaction, teacher commitment to their schools, and commitment to their profession. It also sought to examine any disparity between the teachers' and principals' perception levels of teacher empowerment. This study was not without limitations. The following limitations should be considered when interpreting the findings.

The author was careful to ensure that the sample represented the population relevant to the study. A total of 200 out of 688 K-12 Christian schools in the south central and northwestern regions of the United States were randomly selected to participate in the study. The selected schools were also members of the Association of Christian Schools international (ACSI). A total of 57 schools (representing 28.5%)

accepted the invitation to participate. These schools had a population 653 teachers, and 190 of these responded to the invitation to participate. Of these, 121 completed the surveys, and 89 started but did not complete the surveys. Therefore, only 121 teachers ($N=121$) and 49 principals ($N=49$) were incorporated in the study. The response rate was about 29%, a rate that is not uncommon in social science studies (e.g., Bogler, 1994; Kidder, 2002; William & Shiaw, 1999). Both the size of the sample and the response rate are important factors to consider before making generalization to a larger population. As can be observed, this was not a big sample, but on a positive note, it was a good representation of the population under study and exhibited variables relevant to the empirical enquiry. While a big sample is desirable, the most important characteristic of a good sample is its representativeness, not the size (Ary et al., 2006). However, this author is of the view that the findings of the current study may not be generalized as to reflect K-12 Christian schools in the United States. This is due to the fact that the sample was a very small representation of K-12 Christian schools. A random sample of all K-12 Christian schools in the United States, coupled with an acceptable response rate, may allow such generalization. The present findings, however, provide a sound empirical glimpse of the status of transformational leadership and teacher empowerment in K-12 Christian schools and also open the door for further studies in the K-12 Christian school arena.

The author used research instruments that have been used previously by other researchers. The instruments were reported to have acceptable reliability. However, the instruments use self-report measures. Self-report measures can have common variance and social desirability problems. When using self-report data to measure the

self-perception of individuals, one should bear in mind that they may not reflect the actual performance of the respondents (Spector, 1994).

Summary of the Findings

This study has brought to light very important aspects of transformational leadership and empowerment in K-12 Christian schools. The results from the study depict mixed findings. They indicate that certain elements of transformational leadership and teacher empowerment are prevalent in Christian schools but that others are lacking. Teachers felt strongly empowered in SPES (empowerment) subscales of self-efficacy, status, and impact but less empowered in subscales of decision making, autonomy, and professional growth. This means that K-12 Christian school leaders, while doing a good job of acknowledging teachers' expertise (status) and recognizing importance or effectiveness of their contribution (impact), did not do as much to empower them by allowing participation in decision making or having control of their work life (autonomy). This means that K-12 Christian leaders in this survey maintained a firm grip on leadership and did not allow participative leadership in certain dimensions, especially decision making and autonomy. In order for teachers to be part of the decision-making process, school leaders should solicit their input on issues of school budgets, hiring of new teachers, selection or development of the curriculum, discipline, and other salient matters of school leadership. On the issue of autonomy, teachers in K-12 Christian schools should be given more control of their work life. This can be achieved in a number of ways that might include freedom to select the curriculum, work or class schedules, classes to teach, and responsibilities for extra-curricular activities. Empowerment of followers is a crucial process that both helps define transformational leadership, and

illustrates why it is effective in building follower commitment and inspiring better performance (Bass & Riggio, 2006).

The K-12 Christian school leaders in this study did not appear to do a good job in allowing the teachers to grow professionally. This can be achieved by providing teachers with opportunities for in-service training, paid leave for further studies, scholarship awards, and merit-based promotions. School leaders ought to develop a school culture that is supportive and nurturing in respect to professional growth and personal development. This can be achieved by providing teachers with opportunities to further their education and careers. Transformational leaders show keen interest in the wellbeing of their followers holistically, and this should include both professional and personal attributes. Professional attributes relate to developing teachers' expertise or competencies in pedagogy, curriculum development, and all around leadership acumen. Personal attributes relate to the social, spiritual, and emotional wellbeing of the teacher.

Christian school leaders need to embrace and perpetuate a culture of teacher empowerment in every aspect of shared decision making. As the review of literature has shown, there are many benefits associated with empowerment. Transformational leadership is not based on controlling the decision-making process through a consolidation of power. Control and power are easily open to abuse, but great leaders empower and release others through shared leadership (Kahl, 2004). As observed in the literature review, when employees are empowered, they are more productive and effective. They also show more commitment to the school and profession. This would translate to fewer administrative problems and reduced teacher turnover. It would mean that school resources would be focused on matters that boost optimal student success.

This is especially important when one considers the fact that school resources are generally in short supply.

The literature review has shown transformational leadership continues to be a growing paradigm in business and education, and at the heart of transformational leadership is the concept of empowerment. It has been documented that empowered teachers are more resourceful and more committed to their schools (Ingersoll, 2003). This study, in congruence, found that a positive correlation existed between teacher empowerment and job satisfaction, organizational commitment, and professional commitment. Therefore, transforming principal leadership and the empowerment of teachers that accrues from it should be regarded as an essential paradigm in Christian schools. Christian school leaders who desire to transform their schools so that they can achieve excellent education outcomes and professional growth should foster an enabling environment for teacher empowerment. The leaders should seek to empower teachers through informal sharing of power, delegation, and consultative decision making (Davies, 1993). This should be a formalized, informalized, and even an institutionalized school-wide effort. In addition, Davies (1993) postulated that authentic information sharing among teachers instills a sense of corporate belonging and invigorates them to effectively strive toward corporate goals.

A transformational leader is the one that empowers his followers by sharing power and delegating responsibilities. A transformational leader sets the agenda for the organization, inspiring the followers to pursue common goals for the overall good of the organization. In the words of Kouzes and Posner (2002), a transformational or exemplary leader models the way, inspires a shared vision, challenges the process,

enables others to act, and encourages the heart. It is the view of this author that K-12 Christian school leaders should adopt and execute the aforementioned ideals of authentic transformational leadership.

Recommendations for Future Research

Transformational leadership and the concept of empowerment have attracted considerable empirical interest in the fields of business, politics, and public schools, but it is not the case for Christian education and schools. There is, therefore, the need to expand research studies to encompass the province of Christian education. The present study provided a glimpse of transformational leadership and teacher empowerment in K-12 Christian schools, but the scale of research may not allow for generalization. In retrospect, there is need for a similar study but on a larger scale so as to allow generalization of the findings to the national spectrum.

Future studies may focus on the effects of teacher empowerment on student performance. In addition, future studies may investigate the effects of teacher empowerment as relates to teachers working at different grade levels. This author proposes a study that would investigate the implications of Christian faith for transformational leadership and teacher empowerment. Further investigation should be made into the differences among private, parochial, and public schools. It would be interesting to study the differences in the perception of teacher empowerment by administrators based on gender.

REFERENCES

- Ary, D., Jacobs, L., Razavieh, A., & Sorensen, C. (2006). *Introduction to research in education* (7th ed.). Belmont, CA: Thomson Wadsworth.
- Ashton, P., & Webb, B., (1986). *Making a difference: Teachers' sense of efficacy and student achievement*. New York, NY: Longman.
- Association of Christian Schools International (2007). *ACSI member school listings worldwide*. Colorado Springs, CO: ACSI Publishing.
- Association of Christian Schools International (2008). *Annual school survey 2007-2008*. Colorado Springs, CO: ACSI Publishing.
- Association of Christian Schools International (2008a). *ACSI mission and history*. Colorado Springs, CO: ACSI Publishing.
- Association of Christian Schools International (2008b). *Member directory 2008*. Colorado Springs, CO: ACSI Publishing.
- Association of Christian Schools International. (2009). *Authentic Christian education*. Retrieved from www.acsi.org/Resources/ReferenceLibrary/tabid/568/itemId/12/Default.aspx
- Avolio, B. J., & Bass, B. M. (2002). *Developing potential across a full range of leadership: Cases on transactional and transformational leadership*. Mahwah, NJ: Lawrence Erlbaum Associates Publishers.
- Baker, A. (1990). *The successful Christian school* (2nd ed.). Pensacola, FL: A Beka Book Publications.
- Balfanz, R., & Legters, N. (2004). *Locating the dropout crisis: Which high schools produce the nation's dropouts? Where are they located? Who attends them?*

Baltimore, MD: Center for Social Organization of Schools, Johns Hopkins University.

Banks, R., & Ledbetter, B. (2004). *Reviewing leadership*. Grand Rapids, MI: Baker

Bass, B. M. (1990). From transactional to transformational leadership: Learning to share the vision. *Organizational Dynamics*, (Winter), 19-31.

Bass, B., & Riggio, R. (2006). *Transformational leadership* (2nd ed.). Mahwah, NJ: Lawrence Erlbaum Associates.

Bass, B. M., & Avolio, B. J. (1994). Shatter the glass ceiling: Women may make better managers. *Human Resource Management*, 5, 313-345.

Beare, H., Caldwell, B., & Millikan, R. (1989). *Creating an excellent school: Some new management techniques*. London, UK: Routledge.

Bennis, W. (1989). *On becoming a leader*. New York, NY: Addison Wesley Publishing Company.

Bennis, W., & Nanus, B. (2003). *Leaders: Strategies for taking charge*. New York, NY: Harper Collins Publishers.

Blanchard, K., & Hodges, P. (2003). *The servant leader*. Nashville, TN: J. Countryman.

Blase, J. (1982). A social-psychological grounded theory of teacher stress and burn out. *Educational Quarterly*, 18(4), 93-113.

Blase, J. (1990). Some negative effects of principals' control-oriented and protective political behavior. *American Educational Research Journal*, 27, 727-753.

Blase, J., & Blase, J. (2001). *Empowering teachers: What successful principals do*. Thousand Oaks, CA: Carwin Press.

- Blau, J. (1985). A multiple study investigation of the dimensionality of job involvement. *Journal of Vocational Behavior, 27*, 19-36
- Blau, J. (1987). Using a person-environmental fit model to predict job involvement and organizational commitment. *Journal of Vocational Behavior, 30*, 240-257.
- Blau, J. (1989). Testing the generalizability of a career commitment measure and its impact on employee behavior. *Journal of Vocational Behavior, 35*, 88-103.
- Blau, G., & Boal, K. (1989). Using job involvement and organizational commitment interactively to predict turnover. *Journal of Management, 15*, 115-127.
- Bogler, R., & Somech, A. (2004). Influence of teacher empowerment on teachers' organizational commitment, professional commitment and organizational citizenship behavior in schools. *Teaching and teacher education, 20*(3), 277-289.
- Boles, K., & Troen, V. (1992). How teachers make restructuring happen. *Educational Leadership, 49*(5), 53-56.
- Bolin, F. S. (1989). Empowering leadership. *Teacher College Record, 91*, 81-96.
- Bowling, N., & Hammond, G. (2008). A meta-analytic examination of the construct validity of the Michigan Organizational Assessment Questionnaire Job Satisfaction Subscale (MOAQ-JSS). *Journal of Vocational Behavior, 73*(1), 63-77.
- Bragg, D. (2008). *The application of transformational leadership among Christian school leaders in the southeast and mid Atlantic north regions*. Unpublished manuscript, Department of Education, Liberty University, Lynchburg, Virginia.

- Brown, S. P., & Leigh, T. W. (1996). A new look at psychological climate and its relationship to job involvement, effort, and performance. *Journal of Applied Psychology, 81*, 358-368.
- Brownlee, D. (1979). Characteristics of teacher leaders. *Educational Horizons, 57*(3), 119-122.
- Burns, J. (2003). *Transforming leadership*. New York, NY: Grove Press.
- Burns, J. M. (1978). *Leadership*. New York, NY: Harper & Row Publishers.
- Byham, C., & Cox, J. (1992). *Zapp in education*. New York, NY: Fawcett Columbine.
- Cammann, C., Fichman, M., Henkins, D., & Klesh, J. (1979). *The Michigan Organizational Assessment Questionnaire*. Unpublished manuscript, University of Michigan at Ann Arbor.
- Carnegie Forum on Education and the Economy. (1986). *A nation prepared: Teachers for the 21st century*. New York, NY: Author.
- Carper, J., & Layman, J. (1997). Black-flight academies: The new Christian day schools. *Educational Forum, 61*(2), 114-121.
- Ciulla, J. (Ed.). (2004). *Ethics, the heart of leadership* (2nd ed.). Westport, CT: Praeger Publishers.
- Clinton, R. (1988). *The making of a leader*. Colorado Springs, CO: NavPress.
- Cole, G. (2004). *Management theory and practice* (6th ed.). London, UK: Thomson.
- Conger, J. A., & Kanungo, R. N. (1988). Behavioral dimensions of charismatic leadership. In J. A. Conger & R. N. Kanungo (Eds.), *Charismatic leadership: The elusive factor in organizational effectiveness* (pp. 78-97). San Francisco, CA: Jossey-Bass.

- Covey, R. (1989). *The 7 habits of highly effective people*. New York, NY: Simon and Schuster.
- Creswell, J. W. (1994). *Research design: Qualitative & quantitative approaches*. Thousand Oaks, CA: Sage.
- Crowther, F., & Olsen, P. (1997). Teachers as leaders: An exploratory framework. *International Journal of Education Management, 11*(1), 6-13.
- Davies, K. (1993). *The biblical notion of servanthood: Implications for leadership in Christian schools--Summary report* (Unpublished master's thesis). University of Western Sydney, Australia.
- Dunst, R. (1991, February). *Issues in empowerment*. Paper presented at the annual meeting of Children's Mental Health and Service Policy Convention, Tampa, Florida.
- Eden, D., Avolio, J., & Shimir, B. (2002). Impact of transformational leadership on follower development and performance: Field experiment. *Academy of Management Journal, 45*, 735-744.
- Edwards, L., Green, E., & Lyons, A. (2002). Personal empowerment, efficacy, and environmental characteristics. *Journal of Educational Administration, 40*(1), 67-86.
- Elloy, F., Everett, E., & Flynn, W. (1991). An examination of the correlates of job involvement. *Group and Organization Studies, 16*, 160-177.
- Erlandon, D. A., & Bifano, S. L. (1987). Teacher empowerment: What research says to the principal. *NASSP Bulletin, 71*(503), 31-36.

- Firestone, A., & Pennell, R. (1993). Teacher commitment, working conditions, and differential incentive policies. *Review of Educational Research*, 63(4), 489-525.
- Ford, R. C., & Fottler, M. D. (1995). Empowerment: A matter of degree. *Academy of Management Executive*, 93, 21-31.
- Foster, W. (1986). *Paradigms and promises: New approaches to educational administration*. Buffalo, NY: Prometheus Books.
- Frymier, J. (1987). Bureaucracy and the neutering of teachers. *Phi Delta Kappan*, 69, 9-14.
- Fullan, M. (2007). *Jossey Bass reader on educational leadership*. San Francisco, CA: John Wiley and Sons.
- Gibson, S., & Dembo, M. (1984). Teacher efficacy: A construct validation. *Journal of Educational Psychology*, 76, 569-582.
- Glickman, C. D. (1989). Has Sum and Samantha's time come at last? *Educational Leadership*, 46(9), 4-9.
- Greenleaf, R. (2002). *Servant leadership: A journey in the nature of legitimate power and greatness*. Mahwah, NJ: Paulist Press.
- Griffin, R., & Bateman, S. (1986). Job satisfaction and organizational commitment. In C. L. Cooper & I. Robertson (Eds.). *International review of industrial and organizational psychology* (pp. 157-188). New York, NY: Wiley.
- Gruber, J., & Trickett, J. (1987). Can we empower others? The paradox of empowerment in an alternative public high school. *American Journal of Community Psychology*, 15, 353-372.

- Heesbeen, T., Beeneker, I., & Boer, A. (2008). *Job satisfaction vs. teacher ownership: How to keep teachers satisfied* (Unpublished master's thesis) University of Utrecht, Netherlands.
- Heller, M.F., & Firestone, W.A. (1995). Who's in charge here? Sources of leadership for change in eight schools. *The Elementary School Journal*, 96(1), 65-86.
- House, B. (2009). *Classical Christian education: A look at some history*. Retrieved from http://reformed.org/master/index.html?mainframe=/christian_education/classic_education.html
- Howell, P., & Dorfman, W. (1996). Leadership and substitutes for leadership among professional and non professional workers. *The Journal of Behavioral Science*, 22, 29-46.
- Hyneman, C., & Lutz, D. (1983). Benjamin Rush: Thoughts upon the mode of education proper in a Republic. *In American political writing during the founding era, 1760-1805, 1*, 684. Indianapolis, IN: Liberty Press.
- Iaffaldano, T., & Muchinsky, M. (1985). Job satisfaction and job performance: A meta-analysis. *Psychological Bulletin*, 97, 251-73.
- Ingersoll, R. (2003). *Who controls teachers' work: Power and accountability in America's schools*. Boston, MA: Harvard University Press.
- Kahl, J. (2004). *Leading from the heart*. Westlake, OH: Jack Kahl and Associates.
- Kanungo, N. (1992). Alienation and empowerment: Some ethical imperatives in business. *Journal of Business Ethics*, 11, 413-422.

- Keiser, N. M., & Shen, J. (2000). Principals' and teachers' perception of teacher empowerment. *The Journal of Leadership Studies*, 7(3), 115-121.
- Kelley, E. (1992). *The power of followership*. New York, NY: Currency and Doubleday.
- Kouzes, M., & Posner, B. (1987). *The leadership challenge: How to get extra-ordinary things done in organizations*. San Francisco, CA: Jossey-Bass Publishers.
- Kouzes, J., & Posner, B. (2002). *Leadership challenge*. San Francisco, CA: Jossey Bass.
- Kreisberg, S. (1992). *Transforming power: Domination, empowerment, and education*. Albany, NY: State University of New York Press.
- Krishnan, R. (2005). Transformational leadership and outcomes: Role of relationship duration. *Leadership and Organization Development Journal*, 26(6), 442-457.
- Lee, M. (2006). *Perspective: A Christian worldview on education and family*. Woodstock, GA: Cherokee Christian Schools.
- Lee, W. (1991). Empowering music teachers: A catalyst for change. *Music Educators Journal*, 78(1), 36-39.
- Leedy, P. D. (1989). *Practical research*. New York, NY: Macmillan.
- Lightfoot, L. (1986). On goodness of schools: Themes of empowerment. *Peabody Journal of Education*, 63(3), 9-28.
- Leithwood, K., Jantzi, D. and Steinbach R. (1999). *Changing Leadership for Changing Times*. Buckingham, Philadelphia: Open University Press.
- Locke, E. A. (1976). The nature and causes of job satisfaction. In M. D. Dunnette (Ed.), *Handbook of industrial and organizational psychology* (pp. 1293-1349). Chicago: Rand McNally.

- Lodahl, M., & Kejner, M. (1965). The definition and measurement of job involvement. *Journal of Applied Psychology, 49*, 24-33.
- Lucas, S., Brown, C., & Markus, W. (1991). Principal's perceptions of site-based management and teacher empowerment. *NASSP Bulletin, 75*(357), 56-62.
- Lynch, M., & Strodl, P. (1991, February). *Teacher leadership: Preliminary development of a questionnaire*. Paper presented at the annual conference of the Eastern Educational Research Association, Boston, MA.
- Maeroff, I. (1988). *The empowerment of teachers: Overcoming the crisis of overconfidence*. New York, NY: Teachers College Press.
- Marks, M., & Louis, S. (1997). Does teacher empowerment affect the classroom? The implications of teacher empowerment for instruction practice and student academic performance. *Educational Evaluation and Policy Analysis, 19*, 245-275.
- Marzano, J. (2003). *What works in schools: Translating research into action*. Alexandria, VA: ASCD.
- Masi, R., & Cooke, A. (2003). Transformational leadership and its effects. *International Journal of Organizational Productivity, 8*, 16-47
- Maxwell, J. (2007). *The 21 irrefutable laws of leadership* (Rev. ed.). Nashville, TN: Thomas Nelson.
- McCarty, H. (1993). From deadwood to Greenford: Working with burned out staff. *Journal of Staff Development, 14*(1), 42-47.
- McDowell, S. (2008). *America's schools began with Christian Education*. Retrieved from http://www.forerunner.com/mandate/X0056_Americans_Schools.html

- McKenna, J. F. (1990). Smart scarecrows: The wizardry of empowerment. *Industrial Week*, 239(14), 8-19.
- Melenyzer, S. J. (1990). *Teacher empowerment: The discourse, meaning and social actions of teachers*. Orlando, FL: Emerald Group Publishing.
- Mental Health and Service Policy Convention. (1991, February). Tampa, Florida.
- Mowday, R., Steers, M., & Porter W. (1979). The measurement of organization commitment. *Journal of Vocational Behavior*, 14, 224-247.
- Murphy, J. (2005). *Connecting teacher leadership and school improvement*. Thousand Oak, CA: Corwin Press.
- Murphy, J., & Evertson, C. (1990, April). *Restructuring schools: Capturing the phenomena*. Paper presented at the annual meeting of the American Educational Research Association, Boston, MA.
- National Association of Secondary School Principals. (1996). Breaking ranks: Changing an American institution, a report of NASSP study of the restructuring of the American high school. *NASSP Bulletin*, 80(578), 55-66
- Nguni, S., Slegers, P., & Denessen, E. (2006). Transformational and transactional leadership effects on teachers' job satisfaction, organizational commitment, and organizational citizenship behavior in primary schools: The Tanzanian case. *School Effectiveness and School Improvement*, 17(2), 145-177.
- Noll, M. (1992). *A history of Christianity in the United States and Canada*. Grand Rapids, MI: Wm. B. Erdmann's Publishing Co.
- Owens, R. (2004). *Organization behavior in education: Adaptive leadership and school reform* (8th ed.). Boston, MA: Pearson Education.

- Park, S., Henkin, B., & Egley, R. (2005). Teacher team commitment, teamwork, and trust: Exploring associations. *Journal of Educational Administration, 43*(5) 462-479.
- Patton, D. (2008). *The effect of school size on the utilization of educational technologies*. (Doctoral Dissertation) Retrieved from <http://digitalcommons.liberty.edu/doctoral/127/>.
- Peel, H., & Walker, B. (1994). What it takes to be an empowering principal. *Principal, 73*(4), 41-42.
- Petty, M., McGee, W., & Cavender, W. (1984) A meta analysis of the relationships between individual job satisfaction and individual performance. *Academy of Management Review, 9*, 712-721.
- Porter, L., Steers, M., Mowday, R., & Boulian, P. (1974). Organizational commitment, job satisfaction, and turnover among psychiatric technicians. *Journal of Applied Psychology, 59*, 603-609.
- Pounder, D. G. (Ed.). (1998). *Restructuring schools for collaboration*. Albany, NY: State University of New York.
- Prawat, S. (1991). Conversations with self and settings: A framework for thinking about teacher empowerment. *American Educational Research Journal, 28*, 737-757.
- Quicke, M. (2006). *360-degree leadership*. Grand Rapids, MI: Baker Books.
- Rappaport, J. (1987). Terms of empowerment/exemplars of prevention: Toward a theory for community psychology. *American Journal of Community Psychology, 15*, 121-148.

- Reitzug, C. (1991). A case study of principal empowering behavior. *American Educational Research Journal*, 31, 283-307.
- Rinehart, S., & Short, P. (1994). Job satisfaction and empowerment among teacher leaders, reading recovery teachers, and regular classroom teachers. *Education*, 114(4), 570-580.
- Rosenbach, W. & Taylor, R. (1998). (Eds.). *Contemporary issues in leadership*. Boulder, CO: Westview Press.
- Rosenholtz, S. J. (1991). *Teachers' workplace: The social organization of schools*. New York, NY: Teachers College Press.
- Sarason, B. (1971). *The culture of school and the problem of change*. Boston, MA: Allyn and Bacon.
- Schlechty, P. (1990). *Schools for the 21st century*. San Francisco, CA: Jossey Bass.
- Schlechty, P. (2002). *Working on the work: An action plan for teachers, principals, and superintendents*. San Francisco: Jossey-Bass.
- Schultz, G. (1998). *Kingdom education: God's plan for educating future generations*. Nashville, TN: LifeWay Press.
- Scribner, J. P., Truell, A. D., Hager, D. R., & Srichai, S. (2001). An exploratory study of career and technical education teacher empowerment: Implications for school leaders. *Journal of Career and Technical Education*, 17(2), 46-57.
- Seashore, S. E., Lawler, E. E., III, Mirvis, P. H., & Cammann, C. (1983). *Assessing organizational change: A guide to methods, measures, and practices*. New York, NY: John Wiley & Sons.

- Sergiovanni, T. (1992). *Moral leadership: Getting to the heart of school improvement*. San Francisco, CA: John Wiley & Sons.
- Sergiovanni, T. (2000). *The lifeworld of leadership: Creating culture, community, and personal meaning in our schools*. San Francisco, CA: John Wiley & Sons.
- Shavelson, J. (1988). *Statistical reasoning for the behavioral sciences* (2nd ed.). Boston, MA: Allyn and Bacon.
- Shee, S., Ji, C., & Boyatt, E. (2002). Religiosity in Christian educational leadership. *Journal of Research on Christian Education*, 11(1), 59-86.
- Short, P. (1998). Empowering leadership. *Contemporary Education*, 69(2), 70-72.
- Short, P. M. (1994). Defining teacher empowerment. *Education*, 114(4), 488-492.
- Short, P., Rinehart, J., & Eckley, M. (1999). The relationship of teacher empowerment and principal leadership orientation. *Educational Research Quarterly* 22(4), 45-52.
- Short, P. M., Greer, J. T., & Melvin, W. M. (1994). Creating empowered schools: Lessons in change. *Journal of Educational Administration*, 32(4) 38-52.
- Short, P. M., & Rinehart, J. S. (1992a). School participant empowerment scale: Assessment of the level of empowerment within school environment. *Educational and Psychological Measurement*, 52(4) 951-961.
- Simpson, W. (1990). Keeping it alive: Elements of school culture that sustain innovation. *Educational Leadership*, 47(8), 34-37.
- Slater, R. (1980). New England's first fruits, 1643. In *Teaching and learning America's Christian history* (p. vii). San Francisco, CA: Foundation for American Christian Education.

- Smylie, M.A. (1994). Redesigning teachers work: Connections to the classroom. In H. L Darling. (Ed.), *Review of educational research*, 20 (pp. 129-177). Washington, DC: American Research Association.
- Sofield, L., Kuhn, D., & Leckey, D. (1995). *The collaborative leader*. Notre Dame, IN: University of Notre Dame.
- Southwest Educational Development Laboratory. (2005). Leadership characteristics that facilitate school change. Austin, TX: SEDL. Retrieved from <http://www.sedl.org/change/leadership/character.html>
- Terry, P. (1998). Empowering teachers as leaders. *National Forum of Teacher Education Journal*, 8E(3). Retrieved from <http://www.nationalforum.com/Terryte8e3.html>
- Tichy, N., & Devanna, M. (1986). *The transformational leader*. New York, NY: John Wiley & Sons.
- U.S. Department of Education, National Commission on Excellence in Education. (1983). *A nation at risk: The imperative for educational reform*. Washington, D.C.: Author.
- Veith, G. (1994). *Postmodern times: A Christian guide to contemporary thought and culture*. Wheaton, IL: Crossway Books.
- Wasley, P. A. (1991). String the chalk dust: Tales of three teachers in the midst of change. *Teachers College Record*, (Fall), 28-58.
- Wellins, S., Byham, C., & Wilson, M. (1991). *Empowerment teams: Creating self-directed work groups that improve quality, productivity, and participation*. San Francisco, CA: Jossey Bass.

- Whitaker, T. (1995). Informed teacher leadership--The key to successful change in the middle level school. *NASSP Bulletin*, 79(567), 76-81.
- White, D. (2009). *An Anglican future without Canterbury and Lambeth*. Retrieved from <http://39articles.com/samples.001-virtue.Anglicanfuture.htm>
- Williams, B., & McKibben, M. (1994). *Oriented leadership: Why all Christians need it*. Wayne, NJ: Christian Publications Center.
- Yousef, D. A. (2000). Organizational commitment: A mediator of the relationships of leadership behavior with job satisfaction and performance in non-western country. *Journal of Managerial Psychology*, 133(6), 656-668.
- Zimmerman, A., & Rappaport, J. (1988). Citizen participation, perceived control, and psychological empowerment. *American Journal of Community Psychology*, 16(5), 725-750.. Retrieved from http://www.boston.com/news/education/higher/articles/2006/11/10/haggard_scandal_raises_questions_about_superstar_pastors/?page=1

APPENDICES

Appendix A

School Participant Empowerment Scale

(Copyright 1992 Paula M. Short and James S. Rinehart)

Please rate the following statements in terms of how well they describe how you feel.

Rate each statement on the following scale:

1 = Strongly Disagree

2 = Disagree

3 = Neutral

4 = Agree

5 = Strongly Agree

- | | |
|---|-----------|
| 1) I am given the responsibility to monitor programs. | 1 2 3 4 5 |
| 2) I function in a professional environment. | 1 2 3 4 5 |
| 3) I believe that I have earned respect. | 1 2 3 4 5 |
| 4) I believe that I am helping kids become independent learners. | 1 2 3 4 5 |
| 5) I have control over daily schedules. | 1 2 3 4 5 |
| 6) I believe that I have the ability to get things done. | 1 2 3 4 5 |
| 7) I make decisions about the implementation of new programs in the school. | 1 2 3 4 5 |
| 8) I am treated as a professional. | 1 2 3 4 5 |
| 9) I believe that I am very effective. | 1 2 3 4 5 |
| 10) I believe that I am empowering students. | 1 2 3 4 5 |
| 11) I am able to teach as I choose. | 1 2 3 4 5 |
| 12) I participate in staff development. | 1 2 3 4 5 |
| 13) I make decisions about the selection of other teachers for my school. | 1 2 3 4 5 |

- | | |
|---|-----------|
| 14) I have the opportunity for professional growth. | 1 2 3 4 5 |
| 15) I have the respect of my colleagues. | 1 2 3 4 5 |
| 16) I feel that I am involved in an important program for children. | 1 2 3 4 5 |
| 17) I have the freedom to make decisions on what is taught. | 1 2 3 4 5 |
| 18) I believe that I am having an impact. | 1 2 3 4 5 |
| 19) I am involved in school budget decisions. | 1 2 3 4 5 |
| 20) I work at a school where kids come first. | 1 2 3 4 5 |
| 21) I have the support of my colleagues. | 1 2 3 4 5 |
| 22) I see students learn. | 1 2 3 4 5 |
| 23) I make decisions about curriculum. | 1 2 3 4 5 |
| 24) I am a decision maker. | 1 2 3 4 5 |
| 25) I am given the opportunity to teach other teachers. | 1 2 3 4 5 |
| 26) I am given the opportunity to continue learning. | 1 2 3 4 5 |
| 27) I have a strong knowledge base in the areas in which I teach. | 1 2 3 4 5 |
| 28) I believe that I have the opportunity to grow by working daily with students. | 1 2 3 4 5 |
| 29) I perceive that I have the opportunity to influence others. | 1 2 3 4 5 |
| 30) I can determine my own schedule. | 1 2 3 4 5 |
| 31) I have the opportunity to collaborate with other teachers in my school. | 1 2 3 4 5 |
| 32) I perceive that I am making a difference. | 1 2 3 4 5 |
| 33) Principals, other teachers, and school personnel solicit my advice. | 1 2 3 4 5 |
| 34) I believe that I am good at what I do. | 1 2 3 4 5 |
| 35) I can plan my own schedule. | 1 2 3 4 5 |
| 36) I perceive that I have an impact on other teachers and students. | 1 2 3 4 5 |

37) My advice is solicited by others. 1 2 3 4 5

38) I have the opportunity to teach other teachers about innovative ideas. 1 2 3 4 5

| Subscale | Items |
|---------------------|---|
| Decision making | 1, 7, 13, 19, 25, 30, 33, 35, 37, 38 |
| Professional growth | 2, 8, 14, 20, 26, 31 |
| Status | 3, 9, 15, 21, 27, 34 |
| Self-efficacy | 4, 10, 16, 22, 28, 32 |
| Autonomy | 5, 11, 17, 23 |
| Impact | 6, 12, 18, 24, 29, 36 |

Appendix B

Organizational Commitment Questionnaire (OCQ)

1. I am willing to put a great deal of effort beyond that normally expected in order to help this organization be successful.
2. I talk up this organization to my friends as a great organization to work for.
3. I feel very little loyalty to this organization. (R)
4. I would accept almost any types of jobs assignment in order to keep working for this organization.
5. I find that my values and the organization's values are very similar.
6. I am proud to tell others that I am part of this organization.
7. I could just as well be working for a different organization as long as the type of work was similar. (R)
8. This organization really inspires the very best in me in the way of job performance.
9. It would take very little change in my present circumstance to cause me to leave this organization .(R)
10. I am extremely glad that I chose this organization to work for over others I was considering at the time I joined.
11. There is not much to be gained by sticking with this organization indefinitely. (R)
12. Often, I find it difficult to agree with this organization's policies on important matters relating to its employees. (R)
13. I really care about this organization.
14. For me, this is the best of all possible organizations for which to work.

15. Deciding to work for this organization was a definite mistake on my part. (R)

NOTE: Items denoted by (R) are reverse scored. This instrument can be used in different settings by substituting for “organization” an appropriate word to suit the setting (e.g., school, job, etc).

The internal reliability for OCQ scores was noted to be strong, ranging from 0.82 to 0.93 for six samples (Mowdy et al., 1979).

Source: Mowdy, R. T., Steers, R. M., & Porter, L. W. (1979). Measurement of organizational commitment. *Journal of Vocational Behavior*, 14, 224-247.

Appendix C

Bolin's (1989) Teacher Empowerment Scale

The instrument assesses how much influence teachers have in the following six areas: (a) hiring new full-time teachers, (b) evaluating teachers, (c) setting discipline policy, (d) deciding how the budget shall be spent, (e) establishing curriculum, and (f) determining the content of in-service programs.

This is a self-rating instrument based on a six-point Likert scale and scored as follows:

- 1= No influence
- 2= Very little influence
- 3= Little influence
- 4= Moderate influence
- 5= Much influence
- 6= A great deal of influence

Instructions

Please rate how much influence you feel teachers have in the following areas:

- a. Hiring of new full-time teachers.
- b. Evaluating teachers
- c. Setting discipline policy
- d. Deciding how the budget shall be spent
- e. Establishing curriculum
- f. Determining the content of in-service programs

Appendix D

Job Involvement Questionnaire (JIQ)

(Professional Commitment)

Instructions

Please rate the following statements in terms of how well they describe how you feel.

Rate each statement on the following scale:

1 = Strongly Disagree

2 = Disagree

3 = Neutral

4 = Agree

5 = Strongly Agree

- | | |
|---|-----------|
| 1. The most important things that happen to me involve my present job. | 1 2 3 4 5 |
| 2. To me, my job is only a small part of who I am.(R) | 1 2 3 4 5 |
| 3. I am very much involved personally in my job. | 1 2 3 4 5 |
| 4. I live, eat, and breathe my job. | 1 2 3 4 5 |
| 5. Most of my interests are centered around my job. | 1 2 3 4 5 |
| 6. I have very strong ties with my present job that would be very difficult to break. | 1 2 3 4 5 |
| 7. Usually I feel detached from my job.(R) | 1 2 3 4 5 |
| 8. Most of my personal life goals are job-oriented. | 1 2 3 4 5 |

9. I consider my job to be very central to my existence.

1 2 3 4 5

10. I like to be absorbed in my job most of the time.

1 2 3 4 5

Appendix E

Overall Job Satisfaction

Michigan Organizational Assessment Questionnaire Job Satisfaction Subscale (MOAQ-JSS)

Instructions

Please rate the following statements in terms of how well they describe how you feel.

Rate each statement on the following scale:

1 = Strongly Disagree

2 = Disagree

3 = Neutral

4 = Agree

5 = Strongly Agree

- | | |
|---|-----------|
| 1. All in all I am satisfied with my job. | 1 2 3 4 5 |
| 2. In general, I don't like my job.(R) | 1 2 3 4 5 |
| 3. In general, I like working here. | 1 2 3 4 5 |

Appendix F

Demographics Questionnaire

| Demographics Questionnaire | |
|---|--|
| | |
| Name (Optional)/ Level of education (e.g. Bachelor, Masters) | |
| Gender | |
| Years of service (in school setting) | |
| School size | |

Appendix G

Invitation and Informed Consent

I am making contact to ask for your participation in a research dissertation entitled: *Transformational Leadership: An Exploratory Study of Empowerment of Teachers in Christian Schools and Its Implications on Organizational Commitment and Leadership*. The study was approved by the IRB of Liberty University on August 3, 2009. IRB approval number is 717.06909.

Your name or any other personally identifying marks will not be attached to any of the data. All data gathered and presented will be reported in aggregate. No single response will be identified in any project report.

Further, your participation in this study is entirely voluntary, involving no risk to your physical or mental health beyond those encountered in everyday life, and you may refuse to participate or withdraw from this study at any time without consequence or coercion.

Participation in this study is confidential, and only the researcher listed above will have access to any identity due simply to the making of this contact or invitation. Confidentiality will be maintained in the degree permitted by the technology used. No guarantees can be made regarding the interception of data sent via the internet by any third parties.

Participants are free to remain anonymous.

The benefits of participation include advancement of the scholarship of education.

For questions or synopsis of findings, please contact John I. Kirika at jjkirika@liberty.edu.

If you have any questions regarding your rights as a participant in this research, you may contact the Director of Liberty University Office for Research Protection at 434-592-4054.

Your participation is highly appreciated.

Appendix H

Permission to Use School Participant Empowerment Scale (SPES)

E-mail communications as indicated below:

Hello Drs. Short & Rinehart,

I am a doctoral student at Liberty University planning to do a research on the topic of teacher empowerment in private schools within the context of leadership. On reviewing literature I came across the instrument which you developed called the School Participant Empowerment Scale. I would like to use this instrument, and I guess it is copyright material. Please let me know how I can obtain the permission to use it and also any details on its applications, how scores are tabulated, and any other useful information.

Thanks so much for your help and have happy holidays.

Sincerely,

John Kirika

Hello Dr. Short,

I acknowledge with gratitude the receipt of your email below and thanks for granting permission to use SPES instrument. I will be pleased to send the executive summary when completed.

Again, thank you for your help. Best of regards.

John Kirika.

From: Paula Short [Paula.Short@tbr.edu]

Sent: Tuesday, January 20, 2009 9:03 AM

To: Kirika, John Irungu

Subject: RE: School Participant Empowerment Scale

You have my permission. That will be sufficient since Dr. Rinehart and I agreed that either of us could approve use of the SPES. I have attached a copy of the instrument and scoring directions. The description of the development of the SPES as well as psychometrics can be found in the following article:

Short, P. M., & Rinehart, J. S. (1992). School Participant Empowerment Scale: Assessment of level of participant empowerment. *Educational and Psychological Measurement*, 54(4), 950-961. (Refereed). Please send an executive summary of your study when completed.

Best wishes,

Paula

Paula Myrick Short, Ph.D.

Vice Chancellor for Academic Affairs

Tennessee Board of Regents

1415 Murfreesboro Road

Nashville, TN 37217

615-366-4411

paula.short@tbr.edu

www.tbr.edu

Appendix I

Permission to Use the Organizational Commitment Questionnaire (OCQ)

E-mail communications as indicated below:

RE: Permission to use Organizational Commitment Questionnaire (OCQ) instrument in dissertation research

You forwarded this message on 10/3/2009 6:21 AM.

Rick Mowday [rmowday@lcbmail.uoregon.edu]

Sent: Thursday, August 13, 2009 12:37 PM

To: Kirika, John Irungu

John

The Organizational Commitment Questionnaire (OCQ) was originally developed by Professor Lyman Porter. He decided not to copyright the instrument to encourage its use by others in research. As a consequence, the OCQ exists in the public domain and you do not need formal permission to use it in your dissertation.

I am attaching the appendix to a book we published (“Employee-Organization Linkages”) that might contain information you need to use the instrument.

Good luck with your dissertation.

Rick

From: Kirika, John Irungu [mailto:jikirika@liberty.edu]

Sent: Monday, August 10, 2009 7:55 P

To: Rick Mowday; rsteers@uoregon.edu

Cc: jkirika@gmail.com

Subject: Permission to use Organizational Commitment Questionnaire (OCQ) instrument in dissertation research

Dear Drs. Mowday and Steers,

I am a doctoral student at Liberty University, and I am planning to undertake dissertation research this fall on the topic of empowerment and other constructs within the domain of transformational leadership. One of the instruments I would like to use is the OCQ developed by you, and I am writing this email to request your permission to use it. Also, I would appreciate if you have any information or resource on how to use it appropriately. Thanks in advance for your help in this matter. I look forward to hearing from you soon.

Yours sincerely,

John Kirika

Appendix J

Liberty University IRB Approval Email

From: Institution Review Board

Sent: Thursday, July 30, 2009 3:04 PM

To: Kirika, John Irungu; Pritchard, Tracey Beno; tpritchard@redlionca.org; Garzon, Fernando L.

Cc: Institution Review Board

Subject: IRB Approval Transformational leadership: An exploratory study of empowerment of teachers in Christian schools and its implications on organizational commitment and leadership

Dear John,

We are pleased to inform you that your above study has been approved by the Liberty IRB. This approval is extended to you for one year. If data collection proceeds past one year, or if you make changes in the methodology as it pertains to human subjects, you must submit an appropriate update form to the IRB. Attached you'll find the forms for those cases.

Thank you for your cooperation with the IRB and we wish you well with your research project. We will be glad to send you a written memo from the Liberty IRB, as needed, upon request.

Sincerely,

Fernando Garzon, Psy.D.

IRB Chair, Liberty University

Center for Counseling and Family Studies Liberty University

1971 University Boulevard

Appendix K

Request to Participate in Dissertation Research Email

Dear Sir/Madam,

You are receiving this email because your school has been randomly selected to participate in a dissertation research on the topic of transformational leadership and teacher empowerment in Christian schools. If you are not a school administrator, please forward this email and information to the school administrator/head. Your help is highly appreciated. This survey is strictly confidential and voluntary. The names of the school and the participants are not needed or identified. Survey 1 is for school administrators/heads/principals and their assistants. Survey 2 is for the school teachers. The surveys are in electronic format and take less than 20 minutes to complete. The surveys are accessible by using the links given below. Please remember to click the submit button when finished. I am humbly requesting the school heads to provide the survey links to their assistant heads/administrators and school teachers. Please know that I am counting on you and thank you so much for your time and participation. As an educator I know time is precious and schedules are tight, and I cannot over-emphasize how much I appreciate your help. The research findings might help stakeholders understand and foster even more effective leadership practices in Christian schools. God richly bless you.

Link for Survey 1 for School Administrators/Heads/Principals and their assistants:

<http://www.surveygizmo.com/s/309040/zj0n5>

Link for Survey 2 for School Teachers:

<http://www.surveygizmo.com/s/309045/vd2lh>