

11-2009

Building Online Communities for Literacy Educators

Karen L. Parker

Liberty University, kparker@liberty.edu

Leonard W. Parker

Liberty University, lwparser@liberty.edu

Follow this and additional works at: http://digitalcommons.liberty.edu/educ_fac_pubs



Part of the [Education Commons](#)

Recommended Citation

Parker, Karen L. and Parker, Leonard W., "Building Online Communities for Literacy Educators" (2009). *Faculty Publications and Presentations*. 196.

http://digitalcommons.liberty.edu/educ_fac_pubs/196

This Conference Presentation is brought to you for free and open access by the School of Education at DigitalCommons@Liberty University. It has been accepted for inclusion in Faculty Publications and Presentations by an authorized administrator of DigitalCommons@Liberty University. For more information, please contact scholarlycommunication@liberty.edu.

Building Online Communities for Literacy Educators

Karen L. Parker, Ed.D.

Leonard W. Parker, Ed.D.

Liberty University, Lynchburg, VA

Teaching Reading Well

Six essential features for creating and sustaining preparation programs that produce teachers who teach reading well.

1. Content
2. Faculty and teaching
3. Apprenticeships, field experiences, and practica
4. Diversity
5. Candidate and program assessment
6. Governance, resources, and vision

(IRA, 2007)

Teaching Reading Well

Six essential features for creating and sustaining preparation programs that produce teachers who teach reading well.

1. Content
2. Faculty and teaching
3. Apprenticeships, field experiences, and practica
4. Diversity
5. Candidate and program assessment
6. Governance, resources, and vision

(IRA, 2007)

On-line Learning

- All institutions of higher education
 - 81% at least one internet or blended course
 - 34% complete internet-based degree programs
- Public institutions, even more compelling
 - 97% at least one internet-based course
 - 49% complete internet-based degree program
- Institutional administration
 - 67% view the role of internet-based education as a critical long-term strategy for their institution

(Kushniroff, 2008)

Mentorship

Mentoring

Key component mentioned by a variety of researchers.

(Villar & Alegre, 2007)

Goals of Mentorship

Mentor as Educator

Understanding on-line education

Learning in on-line environment

Discussion

Negotiation

Evaluation

Mentor as LU Liaison

Motivation

Involvement

Scaffolding

Climate

Clarification

Use of resources

Mentoring Model

E-mentoring (electronic mentoring)

- Mentor model for online faculty
 - used as a context for training
- Three-fold mentoring process
 - planning the role of mentors
 - organizing the role of the mentors
 - collection of assessment

(Angulo & De La Rosa, 2006)

One University's Model

- Organizational chart
- Evaluation tools
 - Checklist
 - Student evaluations
 - Self & mentor evaluations
- Summary of data
- Action plan

Organizational Chart

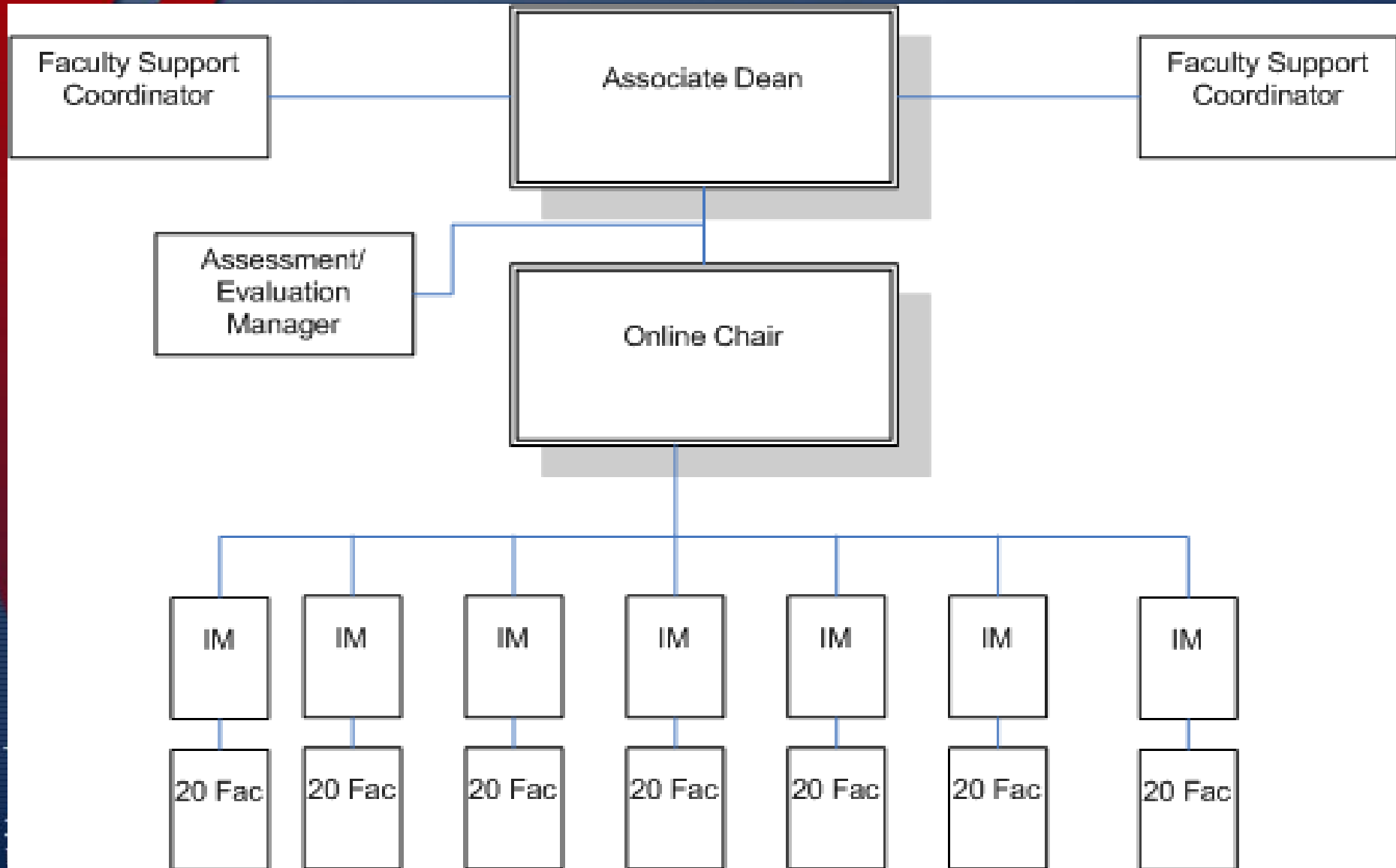

Guidelines for Instructional Mentor (IM)

Communication

- **Online Chair** - post weekly announcements/reminders to Faculty Communication Center (FCC).
- **Online Chair** - mass email additional announcements pertaining to Internet/Blackboard upgrades.
- **Instructional Mentors** - handle any other reminders in addition to the mass emails.
- **Online Consortium** (Blackboard) - share ideas with Instructional Mentors from other departments.

Communication

The screenshot shows a Windows Internet Explorer browser window displaying the Blackboard Academic Suite interface. The address bar shows the URL: http://bb7.liberty.edu/webapps/portal/frameset.jsp?tab=courses&url=/bin/common/course.pl?course_id=

The page header includes the Liberty University logo and navigation links for Home, Help, and Logout. The main content area is titled "NEW FACULTY COHORT" and contains several sections:

- LU Online Modules Directions**
 - FIRST TIME LU Online Faculty**

As you work through your assigned course with your students, we will also organize this training in a similar fashion so we can experience professional growth and collegiality at the same pace. So please work through each of the modules below on the same schedule as your assigned course. Thank you!
 - Veteran's - please just check announcements and discussion posts once a week. Thank you!**
- Home Page Information**

To browse the Homepages of your students, click the Communications button, then click Roster. Choose List All to display all names on the class roster, then click each name to view the Homepage.
- Teaching Respect for Diversity**

to access the curriculum materials:

www.dontlaugh.org Operation Respect is a non-profit organization working to transform schools and organizations focused on youth, into more compassionate, safe and respectful environments. It is the character education & diversity curriculum we are using in the TE program and all faculty members should be familiar with it.

Link to the video that accompanies the program:
http://www.youtube.com/watch?v=vbBWsscli_4

The left sidebar contains a navigation menu with categories like "Announcements", "Information Updates", "Faculty Forms", and "Tools". The Windows taskbar at the bottom shows the Start button, several application icons, and the system clock displaying 12:00 AM.

Guidelines for Instructional Mentor (IM)

Management

- Mark calendar for contacts
 - check with adjuncts at beginning and end of term
 - provide encouragement and advice when needed
- Check classes for quality assurance
- Seek opportunities to encourage and mentor faculty
- Refer administrative questions to Faculty Support Coordinator

Checklist & Data

<u>Assessment of Compliance with Procedure</u>	Percent	
	F 2008	Sp 2009
Welcome Announcement	100	100
Faculty Info.	100	96
Welcome Email	100	100
Module One Weekly Announcements	88	100
Module One Weekly Email	88	100
Logging into Course every 48 hours	100	100
FCC Check-in (Monday)	50	48
FCC Check-in (Thursday)	50	39
Load Calculation Email	100	100
Roster Verification I - Part One	94	100
Module Two Weekly Announcements	75	100
Module Two Weekly Email	81	96
Logging into Course every 48 hours	100	100
FCC Check-in (Monday)	50	48
FCC Check-in (Thursday)	50	48
Roster Verification II	100	100
Module Three Weekly Announcements	75	100
Module Three Weekly Email	75	96
Logging into Course every 48 hours	100	100
FCC Check-in (Monday)	50	70
FCC Check-in (Thursday)	50	43
Module Four Weekly Announcements	81	96
Module Four Weekly Email	81	91
Logging into Course every 48 hours	100	96
FCC Check-in (Monday)	50	39
FCC Check-in (Thursday)	50	43
Module Five Weekly Announcements	75	91
Module Five Weekly Email	75	96
Logging into Course every 48 hours	94	96
FCC Check-in (Monday)	50	48
FCC Check-in (Thursday)	50	43
Module Six Weekly Announcements	75	91
Module Six Weekly Email	81	96
Logging into Course every 48 hours	100	96
FCC Check-in (Monday)	50	61
FCC Check-in (Thursday)	50	57

<u>Assessment of Compliance with Procedure - Cont.</u>	Percent	
	F 2008	Sp 2009
Module Seven Weekly Announcements	81	96
Module Seven Weekly Email	81	91
Logging into Course every 48 hours	100	96
FCC Check-in (Monday)	50	61
FCC Check-in (Thursday)	50	48
Module Eight Weekly Announcements	81	96
Module Eight Weekly Email	81	91
Logging into Course every 48 hours	94	96
FCC Check-in (Monday)	50	48
FCC Check-in (Thursday)	50	43
Posting Final Grades	100	96
No Grade Report		96
Student Evaluation		96
Closing Announcements	100	96
Closing Emails	100	96
Recognition of Existing Incompletes		96
Timely completion of Incompletes		96

Overall Rating

Assessment of Quality of Instruction

5-Point Likert scale for Assessment of Quality of Instruction	
1. Re: Communication w/Students	
a. Proof Read communiqués	4.43
b. Professionalism in framing communiqué	4.6
c. Overall Classroom Management	4.43
2. Feedback	
a. On Grade-book submitted Assignments	4.56
b. Discussion Boards	4.17
3. Community Center Discussion Board	4.05
4. Student Evaluation	4.53
<u>Overall Rating</u>	4.34

Self-Mentor Evaluation Averages

Instructor Self-Evaluation	Scale (Numeric value)	Instructional Mentor Evaluation
My performance exceeds expectations in this area.	(4)	The instructor exceeds expectations in this area.
My performance meets expectations in this area.	(3)	The instructor meets expectations in this area.
My performance is below expectations in this area.	(2)	The instructor's performance is below expectations in this area.
My performance is unsatisfactory in this area.	(1)	The instructor's performance is unsatisfactory in this area.

Performance Criteria for <u>ALL</u> Distance Learning Program Instructors	Instructor Evaluation		IM Evaluation	
	Fall 2008	Spr. 2009	Fall 2008	Spr. 2009
1. Instructor evidences agreement with and ability to integrate a Christian worldview consistent with that of the University into his or her instruction.	3.3	3.48	3.5	3.58
2. Instructor treats students with respect, encourages questions, and demonstrates flexibility in dealing with students.	3.92	3.79	4	3.79
2. Instructor participates in and requires students to participate in focused and meaningful discussions (including but not limited to discussion boards/forums).	3.08	3.41	3.25	3.17
3. Instructor provides meaningful and substantive help to students; responds to email, discussion postings and phone messages within established time standards*; and encourages students to seek assistance when needed.	3.5	3.69	3.7	3.41
4. Instructor understands and follows University and department policies and procedures; treats colleagues and College staff with respect, turns in required documentation and grades on time, etc.	3.6	3.55	3.75	3.72
5. Instructor incorporates course materials/activities to promote listening, speaking, writing, and higher order/critical thinking skills.	3.25	3.38	3.2	3.38
6. Instructor demonstrates enthusiasm for learning as evident by knowledge of subject matter in feedback in grading, discussion boards, and other correspondence with students.	3.6	3.59	3.7	3.69
7. Instructor provides substantive feedback to students on assignments, as appropriate.	3.3	3.55	3	3.21
8. Instructor demonstrates current knowledge of academic discipline and maintains academic standards appropriate to the course.	3.6	3.55	3.5	3.62
9. Instructor keeps accurate and timely records (i.e. grades, attendance roster, test scores, etc.).	3.5	3.55	3.5	3.66
10. Instructor shows consideration for needs of students as evident by accommodations allowed and utilizing various teaching strategies.	3.75	3.48	3.7	3.66
11. Instructor contributes to the success of students at risk and to the retention of all students as evident by feedback and grading.	3.3	3.52	3.2	3.62
12. Instructor encourages active learning by following up on all students to encourage participation.	3.3	3.59	3.3	3.48
13. Instructor maintains professional rapport with students in written and oral communication.	3.5	3.66	3.75	3.76
14. Instructor encourages students to pursue appropriate University services (e.g. learning support, financial aid, etc.).	3.3	3.31	3.3	3.38
15. Overall Effectiveness as a member of the LU DLP Teaching Team.	3.6	3.55	3.5	3.47

RESULTS	ACTION ITEM	Responsible Persons	Completion Date
FCC – More discussion regarding biblical/Christian worldview	Video	Dean/	August 09
FCC – Instructions for using FCC	Video	Dean/ Instructional Technology Faculty	August 09
FCC – information should be updated frequently	FCC information updated	Faculty Support Coordinator	Monthly
DB – Need rubric for grading	Email information to PCM	SMEs	May 2010
DB – Need way of responding without everyone reading professor's posts	Discussion with IT Team	Blackboard 9.0	January 2010
DB – Need to respond to initial threads with substantive, quality comments	Evaluations from IMs/Student evaluations	IMs	Yearly
EMAILS/ANNOUNCEMENTS – Need better instruction for posting announcements/emails	Video/Evaluation s from IMs	Dean	Yearly
EMAILS – Need to be used as positive follow-up and/or suggestions for improvement	Evaluations from IMs/Student evaluations	IMs	Yearly
GRADING – Explanations for assignments should be included earlier	Evaluations from IMs/Student evaluations	IMs	Yearly
GRADING – Correlation between Livetext and assignments should be addressed	Video	Dean	Yearly
GRADING – Feedback should be included with every major assignment	Evaluations from IMs/Student evaluations	IMs	Yearly
GRADING – Should reflect necessity of graduate level thinking and writing	Evaluations from IMs/Student evaluations	IMs	Yearly
GRADING – Feedback should be supportive, positive, substantive, including rationale for grade and suggestions for improvement	Evaluations from IMs/Student evaluations	IMs	Yearly

Action Plan

Review

- Faculty & teaching – essential feature for literacy educators
- Importance of mentoring
- Goals of mentoring
- Organization & job descriptions
- Data collection
- Action plan

Abbreviated Resource List

Angulo, L.V. and De La Rosa. (2006). Online faculty development in the Canary Islands:

A study of E-mentoring. *Higher Education in Europe*, 31, 1, 65-81.

Barone, D. & Morrell, E. (2007). Multiple perspectives on preparing teachers to teach reading. *Reading Research Quarterly*, 42(1), 167-180.

Beretvas, N., Cassidy, J. & Duffy, G. (2003). Prepared to make a difference: An executive summary of the national commission on excellence in elementary teacher preparation for reading instruction. International Reading Association.

Gallen, T., & Oomen-Early, J. (2008). Personalized versus collective courseroom. *International Journal on E-Learning*, 7, 463-476.

International Reading Association. (2007). Teaching reading well: A synthesis of the International Reading Association's research on teacher preparation for reading instruction.

Kushniroff, M. (2008). *Examination and survey of user satisfaction with Internet-based learning compared to traditional Classroom-based learning*. Retrieved from Digital Commons. <http://digitalcommons.liberty.edu/doctoral/91/>

Abbreviated Resource List

- Palloff, R., & Pratt, K. (1999). *Building Learning Communities in Cyberspace: Effective Strategies for the internet-based Classroom*. San Francisco: Jossey-Bass.
- Smith, T., Ferguson, E., Caris, P. (2002). Creating profound communication in virtual classrooms. *Virtual Perspectives*, 3, 19-33. Retrieved December 24, 2007, from Academic Search Premier.
- Villa, L.M. & Alegre, O.M. (2007). The on-line faculty development and assessment system. *Research in Learning Technology*. 3, 217-230.
- Wagner E., Hollman, T., & Gorton, P. (2005) Characteristics of the Adult Learner. *Supplement to the Effective Educator*. 28. 16-24.